

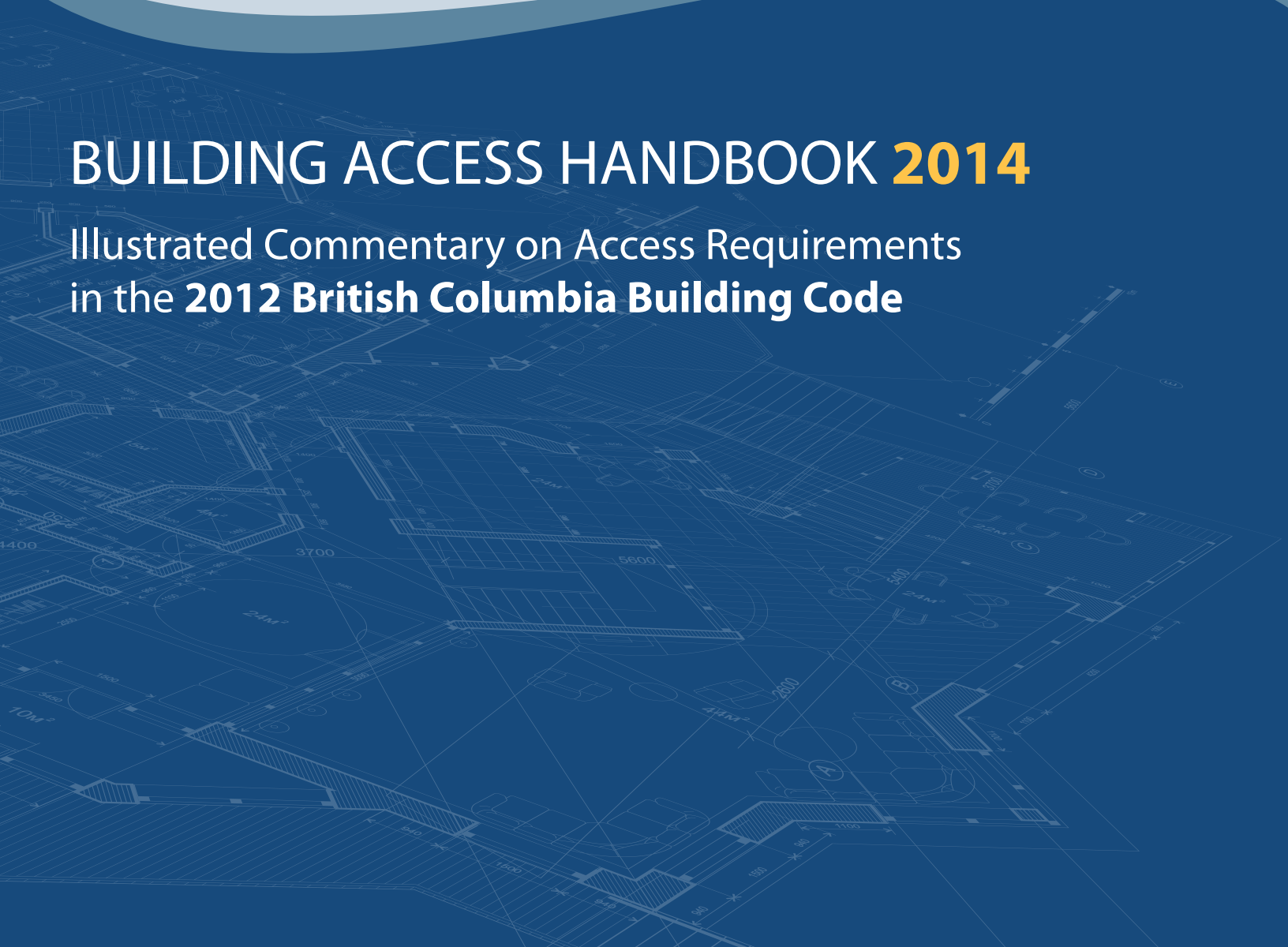

BUILDING ACCESS HANDBOOK **2014**

Illustrated Commentary on Access Requirements
in the **2012 British Columbia Building Code**



The Building Access Handbook

Building Requirements
for
Persons with Disabilities
from
British Columbia Building Code 2012
including
Illustrations and Commentary



National Library of Canada Cataloguing in Publication Data

Main entry under title:

The building access handbook : building requirements for persons with disabilities from British Columbia Building Code 2012 including illustrations and commentary

Running title: Building access handbook 2014.

"Update of the 2007 edition."--P.

ISBN 978-0-7726-5851-7

1. Barrier-free design - Law and legislation - British Columbia - Handbooks, manuals, etc. 2. Building code - British Columbia - Handbooks, manuals, etc. 3. British Columbia. Building Code, 2012. I. British Columbia.

II. Title: Building access handbook 2014.

KEB504.A354B84 2007 343.711'078690087 C2014-960200-2
KF5709.3.H35B84 2007



**Edmund J. Desjardins
C.M., O.B.C., LL.D.
1919 - 1998**

Ed Desjardins was a man who was respected by all who knew him. He was a man of exceptional qualities and ideals who was at the forefront of making buildings accessible.

In the 60's and 70's, there was not much progress in making buildings accessible in North America. To bring the issue into focus, various advocacy groups, with Ed in the thick of it, switched their attention to the potentially powerful legislative process. In 1973, Vancouver adopted a bylaw, "Provisions for the Handicapped," which, after persistent work of advocacy groups, became the forerunner for the 1979 provincial standards. As Ed put it, "building accessibility became a reality a mere thirty-five years after the seeds were sown in 1944."

Ed Desjardins was stationed in England when, just before the D-Day landings, he suffered a spinal injury during paratrooper training that put him into a wheelchair for the remainder of his life. In those days, disabled veterans returning home from the Second World War were confined to institutions in Victoria and Vancouver. Ed was in Shaughnessy Hospital. It was not until the lightweight collapsible wheelchair appeared on the West Coast, around 1945, that things began to change. Wheelchair users gained more freedom; they could stow their wheelchair in a car and get out into the community.

In the same decade, with advancements in medical science and innovations in car controls, people with disabilities were given the opportunity to take part in community life. Then there was the tragic polio epidemic of the 50's that affected so many Canadian families. Rehabilitation experiences

of war veterans proved invaluable in bringing the victims of that disease back into the community — they were disabled, but they were mobile. The Korean conflict simply increased the number of people who were disabled.

All of these events brought into sharp focus a major problem — our buildings and many of our communities were totally inaccessible. Ed Desjardins had found a calling.

Since its adoption in 1979, British Columbia has had a reputation for having some of the most progressive building accessibility standards in North America. This is due in no small measure to Ed and people like him who always looked for ways of incorporating new ideas and technologies into the Building Code. Although there are many who deserve credit for their determination in seeing accessibility regulations become a reality many of them had the feeling that Ed's hand was in there. Especially when a particularly difficult or sensitive issue was the subject of debate between regulation makers and advocacy groups. Ed's presence was never heavy handed, confrontational or subversive, but rather his subtle prodding and posing of intelligent and insightful questions strengthened the advocate's position.

If Ed lost a round in any of the debates that he fought, and he did lose some, he would simply acknowledge the defeat and then prepare for the next battle, perhaps from a slightly different point of view. He never gave up, he was a fighter. He fought for what he believed in: that we shouldn't be satisfied with simply solving the problems directly in our path but should look ahead and work to provide a better future. He was an unselfish man who truly believed and worked for a better life and environment for people with disabilities.

The Building Access Handbook is dedicated to the memory of Ed Desjardins.

Ed Desjardins was appointed in 1948 as the first executive Director of the G.F. Strong Rehabilitation Centre in Vancouver and held that position until he retired in 1979 to become a volunteer consultant. He received some 20 awards during his career. Significant amongst these were the Order of Canada in 1975, a Honourary Doctor of Laws Degree from the University of B.C. in 1981, the Order of British Columbia in 1991 and the Vancouver Civic Merit Award in 1996.

TABLE OF CONTENTS

INTRODUCTION		vii
PREFACE		ix
GENERAL 3.8.1		1
DEFINITIONS OF WORDS AND PHRASES 1.2.1		1
CLASSIFICATION REQUIREMENTS 3.8.2		3
DESIGN REQUIREMENTS 3.8.3		17
ALTERATIONS AND ADDITIONS TO EXISTING BUILDINGS 3.8.4		77
ADAPTABLE DWELLING UNITS 3.8.5		79
APPENDIX 1 Wheelchair Dimensions		81
APPENDIX 2 Anthropometric Data		82
APPENDIX 3 Explanation of Building Use, Building Height and Building Area		83
INDEX		87

INTRODUCTION

It is important for users of the B.C. Building Code to be reminded that the presence and participation of persons with disabilities in our communities is significant. The percentage of persons with disabilities of all ages will increase, especially over the next few decades. This growth will include persons with all types of disabilities, each type having their own specific design needs.

The roles of persons with disabilities in society are ever expanding and need to be recognized. Not only are persons with disabilities receivers of services, they are also providers. For example, they are students and educators, employees and employers, shoppers and merchants, spectators and athletes, residents of buildings and designers of buildings, to name a few. They participate in all aspects of community life and in doing so, utilize all types of buildings.

Users of the code, specifically the sections dealing with building requirements for persons with disabilities, must be aware of the strong impact that proper application of the code has on the day-to-day lives of people with disabilities. Accessibility is paramount.

Thoughtful and careful use of this handbook in applying the building requirements for persons with disabilities will benefit all members of the community.

PREFACE

A Code, if it is to be legally enforceable, must be concise and without explanatory notes or illustrations, except perhaps, in an Appendix. Also a Code cannot be written to cover every situation that will be encountered. Thus, it must be applied with judgement and exercised with good sense and with an awareness of the rationale for the requirements that are being enforced.

The illustrations and commentary in this Handbook have been prepared to assist users of the British Columbia Building Code to understand the diversity and complexity of the “Building Requirements for Persons with Disabilities,” contained in Section 3.8 of Division B and elsewhere throughout the Code.

This Handbook gives users background information on the reasons for certain requirements. It also gives suggestions, through text and illustrations, on how many of the requirements can be implemented. With this kind of information it is hoped that users will have a better understanding of, and appreciation for, the Code requirements for persons with disabilities and be better able to design and construct accessible buildings.

It must, however, be clearly understood that the explanatory text and illustrations contained in the Handbook represent only the views of the contributors. These opinions cannot be construed as providing legal interpretations of requirements contained in the Building Code.

Section 3.8 of Division B comprises a large portion of the requirements of the Code dealing with access for persons with disabilities but there are requirements contained elsewhere in the Code which also pertain to accessibility. Some of these requirements are design specifications for specific facilities such as washrooms, which are contained in Section 3.7, “Health Requirements,” of Division B. Other items originated as requirements for persons with disabilities but have become universal requirements applicable to all building users, not just persons with disabilities. All of these requirements have been included in this handbook in a logical order similar to the first edition of this Handbook published in 1984.

The reference numbers associated with the requirements in this Handbook are the reference numbers from the British Columbia Building Code 2012.

The text of the commentary in this Handbook is printed on a shaded background. The text extracted from the Building Code is printed in the same fonts used in the B.C. Building Code.

The angle brackets (<>) enclosing text indicate changes from the 2006 edition of the British Columbia Building Code

The illustrations in this Handbook were produced by Jim Alders using MiniCad+8 and are based on the original artwork done by Edward J. de Grey, MAIBC, MRAIC, for the 1984 Section 3.7 Handbook.

This edition of the Handbook is primarily an update of the 2007 edition so as to be compatible with the 2012 British Columbia Building Code.

Comments on this Handbook are welcome and can be submitted to Building.Safety@gov.bc.ca

Building Requirements for Persons with Disabilities

from the

British Columbia Building Code 2012 Section 3.8 of Division B

Application

3.8.1. General

3.8.1.1. Application

- 1) This Section applies to the design and construction of *buildings* and *occupancies* to make them *accessible* by *persons with disabilities*.
- 2) The requirements of this Section take precedence over other requirements contained in this Part or Part 9.
- 3) *Access* shall be provided to *alterations*, additions and changes in occupancy to the extent required in Subsection 3.8.4. [p. 77]

Section 3.8 is the portion of the Building Code which tells a designer what buildings or portions of buildings must be accessible to persons with disabilities and how accessible they must be. Section 3.8 also contains most of the details on how to make those buildings accessible but it also refers the designer to other parts of the Code which contain details on how to make specific facilities accessible to persons with disabilities.

Definitions

1.2.1. Definitions of Words and Phrases

Words in *Italics* are defined in Part 1 of Division A of the B.C. Building Code. Several defined words or terms are specific to accessibility and are listed below for convenience.

Access or *accessible* means that a *person with disabilities* is, without assistance, able to approach, enter, pass to and from, and make use of an area and its *facilities*, or **<** both, as required by this code **>**.

Building of new construction means a new *building* constructed as a separate entity, or an addition to an existing *building* where the addition has no internal pedestrian connection with the existing *building*. (See Subsection 3.8.4.) [p. 77]

The definition “building of new construction” is included as a means of separating new buildings from additions to existing buildings for the purposes of accessibility. “Buildings of new construction” applies both to buildings that are erected independently of other buildings, and to additions to existing buildings where there is no “internal pedestrian connection” between the existing building and the addition. The phrase “internal pedestrian connection” is intended to apply to paths of travel normally used by the

principal occupants of the building and includes stairs, corridors, and elevators. The definition would also be applicable to additions to existing buildings where the addition was totally independent in terms of day-to-day operations, exiting requirements, accessibility, and so forth. In Figure 3.8.1., Plan 'A' and Section 'C' show examples of "buildings of new construction" where there is no internal pedestrian connection between the existing building and the addition. In these instances Subsection 3.8.2. would be applicable to the addition.

"Building of new construction" would not, for example, apply to the added third storey of an existing two storey department store as there would be both a functional connection and, in all likelihood, an internal pedestrian connection between the two. Plan 'B' and Section 'D' of Figure 3.8.1. illustrate examples of when Subsection 3.8.4. would be applicable.

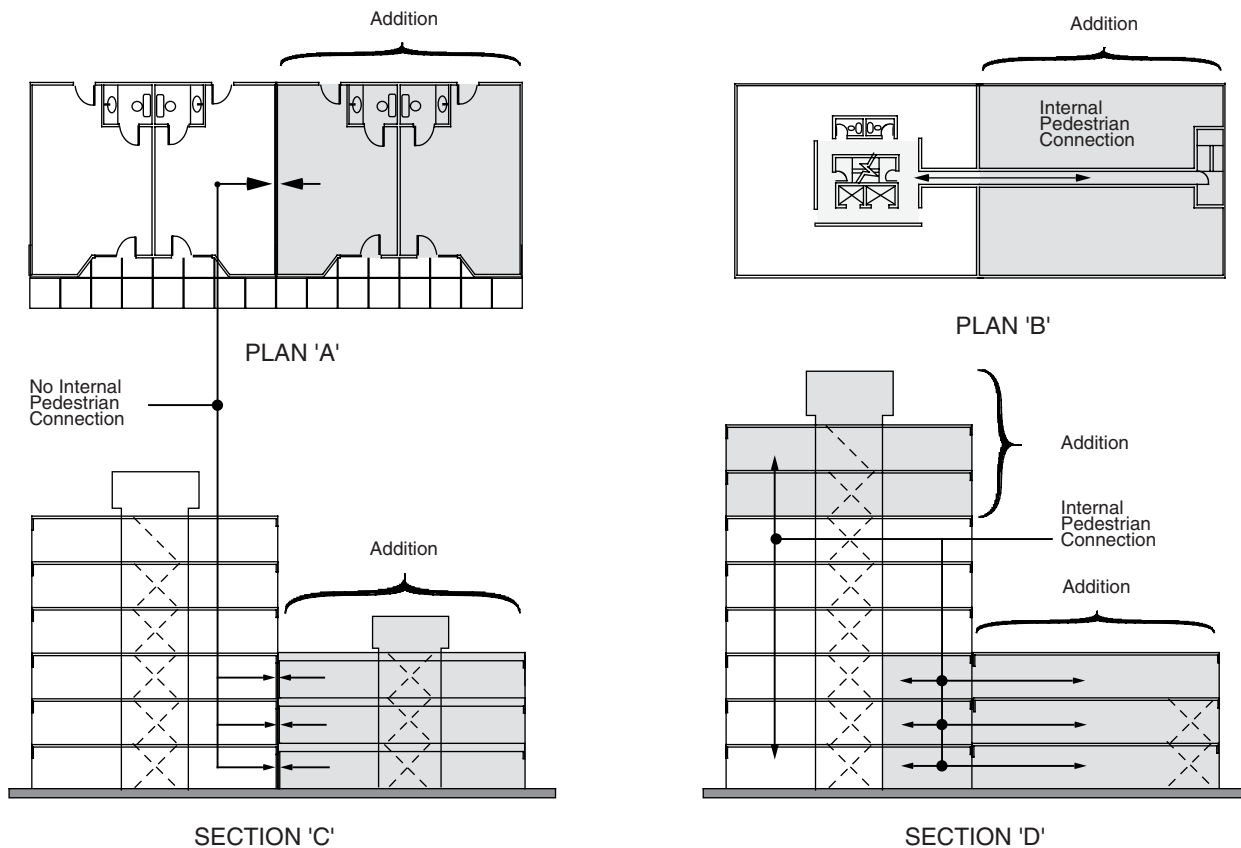

FIGURE 3.8.1. – Buildings of New Construction

Persons with disabilities means a person who has a loss, or a reduction, of functional ability and activity and includes a person in a wheelchair and a person with a *sensory disability*.

Facility means something that is built, installed, or provided to serve a particular purpose.

Sensory disability includes visual and hearing impairments.

3.8.1.2. Openings through Firewalls

1) Where there are openings through a *firewall*, other than those for piping, tubing, wiring and conduit, the requirements of this Section shall apply to the *floor areas* on both sides of the *firewall* as if they were in the same *building*.

3.8.2. Classification Requirements

3.8.2.1. Application and Exemptions

1) Except as provided in Sentence (2), *access* shall be provided to all *storeys* of *buildings of new construction*.

2) This subsection does not apply to

- a) the *storey* next above or below the *accessible storey* in a *building* not more than two *storeys* in *building height* provided the *storeys* next above or below the *accessible storey*
 - i) <is less than 600 m² in *floor area*
 - ii) does not contain *facilities* integral to the principle function of the *accessible storey* and
 - iii) does not contain an *assembly major occupancy* with an area more than 100 m²,
- b) the *storey* next above or below the *accessible storey* in a *suite* of not more than two *storeys*, where the *accessible storey* is the first *storey* or *basement*, provided the *storey* next above or below the *accessible storey*
 - i) is less than 600 m² in area,
 - ii) does not contain *facilities* integral with the principle function of the *accessible storey*, and
 - iii) does not contain an *assembly major occupancy* with an area more than 100 m²,

Elevators and elevating devices for persons with disabilities are relatively expensive and in small buildings are difficult to justify because they may form a significant percentage of a building's cost. Clauses (a) and (b) are intended to exempt such small second storeys or basements from access requirements when they are self-contained or contain the same facilities as on the first storey. Examples where access is not required are office tenants on the second storey of a small building and the second storey of a restaurant which contains only additional seating. If, on the other hand, the restaurant's washrooms are in the less than 600 m² basement there must be access to them as they are an integral part of the principle function on the first storey. Likewise, staff lunchrooms and washrooms are integral with the principle function and when they are on a small second storey or mezzanine they must be accessible when a person with disability could reasonably be expected to be employed there.

This exemption applies to buildings not more than two storeys high containing not more than three floors (2 storeys and basement). A three storey building must be accessible.

Although this access exemption is not seen as being in conflict with the B.C. Human Rights Act it is conceivable that such lack of access may be seen by the Human Rights Council or the courts as an unreasonable barrier to employment in, or use of, a building. An owner may be ordered to make reasonable provisions for persons with disabilities even though the Code exempted the building in the first instance.

- c) Group C *dwelling units*, row houses, boarding houses and lodging houses,

- d) Group C apartment *buildings* and condominiums except to the extent described in Article 3.8.2.27., [p. 12]
- e) Group E shops and stores with a total retail floor space of less than 50 m², and >

Any individual store or shop with a total retail floor space of less than 50 m² is exempt from the requirements for access. A building such as a shopping mall could contain several such stores and each would be exempt from the access requirements although other large stores and the shopping mall itself must be accessible.

- f) Group F, Division 1 *occupancies*.

3.8.2.2. Design Requirements

1) To meet the requirements of Articles 3.8.2.3. to 3.8.2.39., the design requirements of Subsection 3.8.3. shall form an integral part of this Subsection.

3.8.2.3. Specific Requirements

1) Except where stated otherwise *buildings* and *occupancies* to which this Subsection applies shall, in addition to the requirements listed for specific *occupancies*, have

- a) *access* from the *street* to at least one main entrance conforming to Article 3.8.3.5., [p. 27]

Persons with disabilities can arrive at a building by any one of several means. They can drive their own car, be driven by someone else, use public transportation, or arrive using a wheelchair or by walking. Although only one main entrance, and possibly an additional entrance from a parking lot, is required to be accessible, it is preferable that all, or as many as possible, of the main entrances be accessible, particularly in larger buildings and complexes.

- b) where off-street parking is provided for *persons with disabilities*, < *access* > from the parking area to an entrance conforming to Article 3.8.2.35. [p. 26] < that > serves the parking area unless the entrance in Clause (a) is located so as to conveniently serve both the parking area and the *street*,

If parking stalls for persons with disabilities are located close to the entrance to a parking area which, in turn, is close to the main entrance described in Clause (a), there is no requirement to make the secondary entrance from the parking area accessible. If, on the other hand, parking stalls for persons with disabilities are located on an entirely different level from the main entrance and there is a secondary entrance to the building from that level, then it is required to be accessible.

- c) *access* to all areas where work functions can reasonably be expected to be performed by *persons with disabilities*,
- d) *accessible* washrooms conforming to Sentence (2), and
- e) on each *floor area* to which *access* is required, egress conforming to Article 3.8.3.19. [p. 73]

A floor area that is accessible must provide persons with disabilities an acceptable degree of safety in an emergency situation. This is best achieved by making the exits accessible (at grade or ramps to grade) or by providing automatic fire sprinklers. The various options are explained in the commentary to Article 3.8.3.19.

- 2) In *buildings* and *occupancies* where water closets are required
 - a) at least one universal toilet room <that> conforms to Sentence 3.7.2.10.(9) <shall be provided>, and
 - b) where the occupant load of the *building* or *occupancy* exceeds 150, other public washrooms in *floor areas* required to be *accessible* shall conform to Sentences 3.7.2.10. (2) to (8). [p. 55]

Where access to a building, or part of it, is provided, washrooms that serve those areas must conform to Clauses 3.8.2.3.(2)(a) and (b).

The requirements for washroom facilities for persons with disabilities should be incorporated into the regular washrooms required by the code and are applicable to both sexes.

In situations which have male and female washrooms, each with a single water closet, and a third washroom for the staff, it is considered reasonable for one washroom to be designed as a male/female washroom for persons with disabilities.

There are a significant number of persons with disabilities whose daily lives depend on assistance from a companion who may be of the opposite sex. This companion is precluded from assisting in multiple stall public washrooms. The universal toilet room required by Clause (a) not only solves this problem but also serves the needs of other persons with disabilities who prefer the relative ease of using a toilet room. It can also serve as a family washroom for parents with small children and, with the addition of a counter, as a changing room for infants (the counter must not interfere with access). This toilet room is in addition to the accessible multiple stall washrooms that would be required when the occupant load exceeds 150. A universal toilet room is the basic minimum requirement for accessible washrooms and at least one is required in every building required to be accessible. When the occupant load exceeds 150 and washrooms are provided for the general public on an accessible floor, the washroom(s) must conform to Sentences 3.7.2.10.(2) to (8). [p. 55]

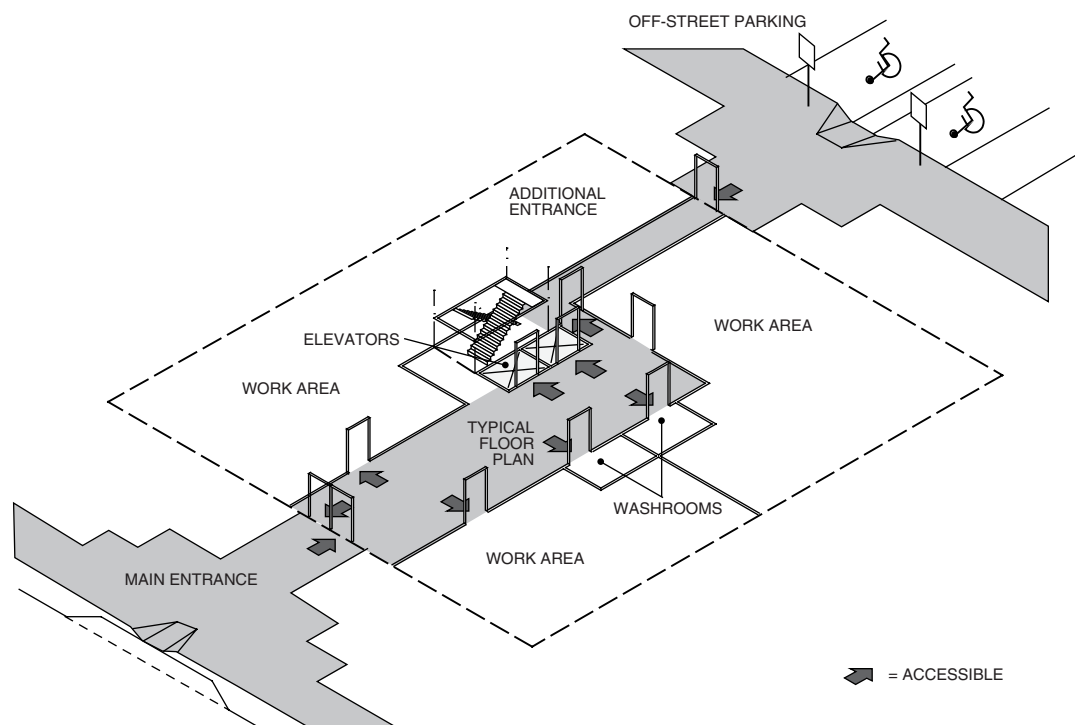

FIGURE 3.8.2. – Specific Requirements

Assembly Occupancies, Division 1

3.8.2.4. Assistive Listening Systems

1) In *assembly occupancies*, all auditoria and *theatres* with an area of more than 100 m² shall have an assistive listening system conforming to Article 3.8.3.20. [p. 76]

3.8.2.5. Theatres, Studios and Opera Houses

1) In Group A, Division 1 *occupancies*, *access* shall be provided to

- a) a ticket office,
- b) each type of refreshment *facility*,
- c) each type of public *facility*, and
- d) viewing positions conforming to Article 3.8.3.15. [p. 69] in the numbers required by Table 3.8.2.5.

Table 3.8.2.5. Required Number of Viewing Positions in Theatres, Studios and Opera Houses Forming Part of Sentence 3.8.2.5.(1)	
Seating Capacity of Occupancy ⁽¹⁾	Number of Viewing Positions Required ⁽¹⁾
Up to 100	2
101 to 200	3
201 to 350	4
351 and over	4 plus 1 for each additional 1 000 seats or part thereof

Note to Table 3.8.2.5.

⁽¹⁾ See Parts 2 and 3 of Division A.

Assembly Occupancies, Division 2

3.8.2.6. Art Galleries, Exhibition Halls, Libraries and Museums

1) In art galleries, exhibition halls, libraries and museums, *access* shall be provided to all areas to which the public is admitted.

Access for persons in wheelchairs need not be provided to proprietary library stacking systems.

3.8.2.7. Bowling Alleys

1) In bowling alleys, *access* shall be provided to

- a) viewing positions conforming to Article 3.8.3.15., [p. 69]
- b) each type of refreshment *facility*, and
- c) all bowling lanes.

Multiple levels in a floor area or suite should be avoided but, this is not always possible. Persons with disabilities must have access to all the services and facilities offered. The non-accessible levels cannot contain facilities or services unavailable elsewhere on the storey or in the suite. For example, if pool tables are provided in a bowling alley they must be accessible along with the bowling and refreshment facilities.

3.8.2.8. Amusement Arcades and Billiard Halls

- 1) In amusement arcades and billiard halls, *access* shall be provided to
 - a) each type of recreational facility, and
 - b) each type of refreshment *facility*.

See comment under Sentence 3.8.2.7.(1) above.

3.8.2.9. Churches

- 1) In churches, similar places of worship and auxiliary halls, *access* shall be provided to viewing positions conforming to Article 3.8.3.15. [p. 69] where fixed seating is installed.

3.8.2.10. Clubs, Non-residential

- 1) In non-residential clubs, *access* shall be provided to
 - a) < each > type of membership *facility*, and
 - b) at least one bath or shower, conforming to Sentence 3.7.2.10.(10) or (11) [p. 63] where one or more baths or showers are provided.

See comment under Sentence 3.8.2.7.(1) on previous page.

3.8.2.11. Community, Dance and Lecture Halls

- 1) In community halls, dance halls and lecture halls, *access* shall be provided to
 - a) each type of public *facility*, and
 - b) viewing positions conforming to Article 3.8.3.15. [p. 69] where fixed seating is installed.

3.8.2.12. Courthouses

- 1) In courthouses, *access* shall be provided to
 - a) each public *facility*,
 - b) interview rooms, and
 - c) at least one holding room.

3.8.2.13. Gymnasiums

- 1) In gymnasiums, *access* shall be provided to
 - a) every type of public *facility*,
 - b) viewing positions conforming to Article 3.8.3.15. [p. 69] where fixed seating is installed, and
 - c) at least one changing room for each sex, where changing rooms are provided.

2) Changing rooms in Clause (c) shall each have at least one shower conforming to Sentence 3.7.2.10.(11), [p. 65] where showers are provided.

3.8.2.14. Restaurants

1) In restaurants

- a) *access* shall be provided to all public *facilities*, and
- b) <each area providing seating shall be capable of providing clear space for use by persons in wheelchairs that is equivalent to not less than 1 per cent of such seating and is located so as
 - i) to provide viewing of any entertainment areas, and
 - ii) not to infringe on any aisle requirements.>

See comment under Sentence 3.8.2.7.(1) on page 6.

3.8.2.15. Lodge Rooms

1) In lodge rooms, *access* shall be provided to all *storeys*, except those storeys containing only mechanical and storage areas.

See comment under Sentence 3.8.2.7.(1) on page 6.

3.8.2.16. Passenger Terminals

1) In passenger terminals, *access* shall be provided to all areas to which the public is admitted.

3.8.2.17. Schools and Colleges, Non-residential

1) Non-residential schools and colleges need not comply with Sentence 3.8.2.3.(1) but shall have

- a) <to each administrative, educational, and recreational *building*, at least one entrance that >
 - i) conforms to Article 3.8.3.5., [p. 27] and
 - ii) is *accessible* from adjacent parking stalls conforming to Article 3.8.3.4. [p. 25], and

It is the intent of Clause 3.8.2.17.(1)(a) to have the buildings (including portables) of a school or college accessible. Where there are several buildings with parking areas, parking stalls should be designated to accommodate students or staff with disabilities at all buildings. In addition, parking for visitors with disabilities should be considered.

See comment under Article 3.8.3.4.(1). [p. 25]

- b) from within each *building*, *access* to
 - i) all educational and recreational *facilities*,
 - ii) each type of refreshment *facility*,
 - iii) offices,

- iv) lockers,
- v) areas where work functions can reasonably be expected to be performed by *persons with disabilities*,
- vi) viewing positions conforming to Article 3.8.3.15. [p. 69] where fixed seating is installed,

The number of students with disabilities can vary greatly from school to school and between semesters at the same school. For this reason no specific number of viewing positions are required. Rather it is recommended that viewing positions be provided as needed.

- vii) *accessible* washrooms conforming to Sentence 3.8.2.3.(2), where washrooms are required, [p. 5] and

The requirements for washrooms in schools apply to both student and staff facilities, although discretion may be shown in the number of washroom facilities for staff with disabilities. In children’s washrooms variations in heights of fixtures and grab bars are permitted. (See Sentence 3.7.2.10.(12), [p. 66]). There is no reason, with proper consideration, why the additional toilet room required by Sentence 3.8.2.17.(2), cannot serve both student and staff needs.

- viii) at least one bath or shower, conforming to Sentence 3.7.2.10.(10) or (11) [p. 63] where one or more baths or showers are provided.

2) In addition to the washroom *facilities* required by Subclause (1)(b)(vii), an *accessible* toilet room conforming to Sentence 3.7.2.10.(9) [p. 62] shall be provided in each principal *building* at a non-residential school or college.

Schools and colleges quite often have more than one building within their grounds. The requirement for an accessible toilet room in Sentence (2) above is intended to apply to the principal buildings. This could, in a large school or college complex, include the main classroom block(s), the auditorium/gymnasium block, the science wing, “temporary” portable buildings and so forth. It should not be construed as including minor out-buildings, either permanent or temporary, buildings or parts of buildings which students or staff with disabilities would not normally use, or where a staff person with a disability would not be employed, e.g., a physical plant building.

3) In addition to the requirements of Sentence (1) every *floor area* <that> is required to be *accessible* shall conform to Article 3.8.3.19. [p. 73]

See comment under Clause 3.8.2.3.(1)(e) on page 4 regarding safety requirements within floor areas.

3.8.2.18. Undertaking Premises

1) In undertaking premises, where <fixed> seating is installed in the chapel, *access* shall be provided to viewing positions conforming to Article 3.8.3.15. [p. 69]

Assembly Occupancies, Division 3

3.8.2.19. Arenas and Ice Rinks

- 1) In arenas and ice rinks, *access* shall be provided to
 - a) each type of public *facility*,
 - b) at least one changing room for each sex, where changing rooms are provided, and
 - c) viewing positions conforming to Article 3.8.3.15. [p. 69] in the numbers required by Table 3.8.2.19., where fixed seating is installed.

Table 3.8.2.19. Required Number of Viewing Positions in Arenas and Ice Rinks Forming Part of Sentence 3.8.2.19.(1)	
Seating Capacity of Arena <or> Ice Rink	Number of Viewing Positions <Required>
Up to 500	3
501 to 1 000	6
1 001 and over	6 plus 2 for each additional 1 000 seats or part thereof

- 2) Changing rooms in Clause (b) shall each have at least one shower conforming to Sentence 3.7.2.10.(11), [p. 65] where showers are provided.

3.8.2.20. Swimming Pools

- 1) Swimming pools shall conform <to> the requirements of Article 3.8.2.13. [p. 7]

Assembly Occupancies, Division 4

3.8.2.21. Bleachers

- 1) Where bleachers are erected as other than temporary structures they need not comply with Sentence 3.8.2.3.(1), but shall have *access* provided to
 - a) viewing positions adjacent to such structures conforming to Article 3.8.3.15. [p. 69] in the numbers required by Table 3.8.2.19., and
 - b) washroom *facilities* conforming to Sentence 3.8.2.3.(2) [p. 5] where washroom *facilities* are provided.

3.8.2.22. Grandstands and Stadiums

- 1) In grandstands and stadiums, *access* shall be provided to
 - a) at least one refreshment *facility*,
 - b) offices,
 - c) at least one changing room for each sex, where changing rooms are provided, and
 - d) viewing positions conforming to Article 3.8.3.15.[p. 69] in the numbers required by Table 3.8.2.19.

- 2) Changing rooms in Clause (1)(c) shall each have at least one shower conforming to Sentence 3.7.2.10.(11) [p. 65], where showers are provided.

3) Where general seating areas are partially or totally covered, viewing positions required by Clause (1)(d) shall be covered.

3.8.2.23. Drive-in Theatres

1) Drive-in theatres need not comply with Sentence 3.8.2.3.(1), [p. 4] but *access* shall be provided to,

- a) all public refreshment *facilities*, and
- b) washroom *facilities* conforming to Sentence 3.8.2.3.(2). [p. 5]

Care & Detention Occupancies, Division 1

3.8.2.24. Jails

1) Jails, penitentiaries, prisons and reformatories need not comply with Sentence 3.8.2.3.(1) [p. 4], but shall have

- a) *access* from the *street* to at least one main entrance conforming to Article 3.8.3.5., [p. 27]
- b) where off-street parking is provided for *persons with disabilities*, *access* from the parking area to an additional entrance conforming to Article 3.8.3.5. unless the entrance in Clause (a) is located so as to conveniently serve both the parking area and the *street*,
- c) *access* to areas where visitors are admitted, and
- d) *access* to visitors washrooms, conforming to Sentence 3.8.2.3.(2) [p. 5], where visitors washrooms are provided.

3.8.2.25. Psychiatric Hospitals and Police Stations

1) Psychiatric hospitals with or without detention quarters, and police stations with detention quarters, need not comply with Sentence 3.8.2.3.(1) [p. 4], but shall have

- a) *access* from the *street* to at least one main entrance conforming to Article 3.8.3.5. [p. 27],
- b) where off-street parking is provided for *persons with disabilities*, *access* from the parking area to an additional entrance conforming to Article 3.8.3.5. unless the entrance in Clause (a) is located so as to conveniently serve both the parking area and the *street*,
- c) *access* to areas where work functions can reasonably be expected to be performed by *persons with disabilities*,
- d) *accessible* public washrooms conforming to Sentence 3.8.2.3.(2) [p. 5] serving each area to which *persons with disabilities* are provided *access*, and
- e) *access* to each type of *facility*.

Care & Detention Occupancies, Division 2

3.8.2.26. Care < and Treatment > Facilities

1) All *occupancies* in Group B, Division 2 < and 3 > shall comply at least with the requirements of Article 3.8.2.25. (See Sentence 3.7.2.10.(12)) [p. 66]

The requirements of Article 3.8.2.26. are not intended to apply to additional features that may be required to meet the special needs of the occupants of health care facilities. Some examples of these features are lower fixtures in facilities intended mainly for children, handrails in corridors for persons with mobility or strength impairments, special furnishings to meet particular requirements, private bathrooms in homes for the aged, and hoists at baths and hydro-massage pools. Bathrooms connected to patient wards and sleeping rooms may also be specially equipped. Having clarified that Article 3.8.2.26. does not apply to additional features provided for special purposes it must be remembered that health care facilities must provide access for both visitors and patients. This would include such facilities as patient bedrooms, public washrooms, lounges and recreation areas, cafeteria, gift shop and other areas which visitors and patients use without assistance from health care staff.

Residential Occupancies

3.8.2.27. <Apartment and Condominium Building>

1) Apartment and condominium *buildings* need not comply with Sentence 3.8.2.3.(1) [p. 4], except that *access* shall be provided

- a) from the *street* to the main entrance conforming to Article 3.8.3.5., [p. 27]
- b) from a private parking area to an entrance conforming to Article 3.8.3.5., and
- c) where an elevator is provided, from the main entrance in Clause (a), or from the entrance in Clause (b), to an elevator conforming to Article 3.5.2.1.(3). [p. 37]

When an apartment building has a secondary entrance from a private parking area, it is required to be accessible. Figure 3.8.3. shows accessible secondary entrances from both the exterior and the underground parking areas and, although this is preferred, only one secondary entrance is required to be accessible. Where parking is provided for persons with disabilities it should be close to an accessible entrance. Signage may be needed to direct persons with disabilities to the accessible entrance(s).

Note that access is required to and including the elevator. Therefore, the path of travel to the elevator must be accessible.

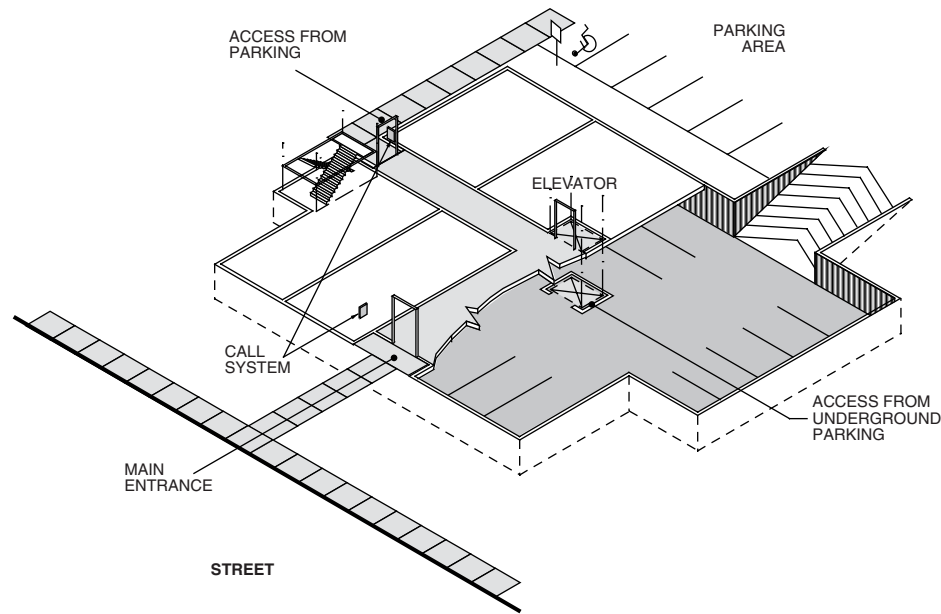

FIGURE 3.8.3. – Apartment Buildings

2) At the main entrance to an apartment or condominium *building*, the intercom system shall be installed with no user functions located more than 1 375 mm above the finished paved area.

3) Each *dwelling unit* in an apartment or condominium *building* designed for senior citizens and each adaptable *dwelling unit*, shall be provided with special outlet boxes and cover plates as described in Sentence 3.2.4.20.(7). [p. 50] (See also Sentence 3.2.4.20.(8)) [p. 50]

3.8.2.28. Clubs, Residential

- 1)** In residential clubs, the requirements of Article 3.8.2.10. [p. 7] shall apply, and
 - a) where sleeping accommodation for 10 or more persons is provided in single or double rooms, at least one such room shall conform to Article 3.8.3.14.[p. 66], and
 - b) a sleeping room other than one required in Clause (a) shall be <equipped> with a visual warning system conforming to Sentence 3.2.4.20.(3). [p. 47]

3.8.2.29. Schools and Colleges, Residential

- 1)** Residential schools and colleges need not comply with Sentence 3.8.2.3.(1), except that the requirements of Article 3.8.2.17. [p. 8] shall apply, and
 - a) *access* shall be provided to at least one bed space conforming to Clauses 3.8.3.14.(1)(a) and (b) [p. 66], for every 40 bed spaces or part thereof, and
 - b) a bed space other than one required in Clause (a) shall be <equipped> with a visual warning system conforming to Sentence 3.2.4.20.(3). [p. 47]

2) A bathroom provided to serve a bed space described in Clause (1)(a) shall conform to Clause 3.8.3.14.(1)(h). [p. 66]

3.8.2.30. Dormitories

- 1)** In dormitories, *access* shall be provided to

- a) each type of *facility*,
- b) at least one bed space conforming to Clauses 3.8.3.14.(1)(a) and (b) [p. 66], for every 40 bed spaces or part thereof, and
- c) at least one bath or shower conforming to Sentences 3.7.2.10.(10) or (11) [p. 63] where one or more baths or showers are provided.

2) A bed space other than <one required by> Clause (1)(b) shall be <equipped> with a visual warning system conforming to Sentence 3.2.4.20.(3). [p. 47]

3) A bathroom provided to serve a bed space described in Clause (1)(b) shall conform to Clause 3.8.3.14.(1)(h). [p. 67]

3.8.2.31. Hotels and Motels

1) In hotels and motels, *access* shall be provided to

- a) every type of public *facility*, including those located outside the *building*,
- b) all *storeys* to which the public is admitted, and
- c) one sleeping unit conforming to Article 3.8.3.14. [p. 66] for every 40 sleeping units or part thereof.

2) At least one sleeping unit, other than those required <by> Clause (1)(c), for every 20 sleeping units or part thereof shall be <equipped> with a visual warning system conforming to Sentence 3.2.4.20.(3). [p. 47]

Note that this Sentence requires the room(s) for the hearing disabled to be separate from the wheelchair accessible room.

3) *Accessible* washrooms required by Clause 3.8.2.3.(1)(d) [p. 4] need only be those provided for public use.

“Public facility” includes the registration desk which needs to be lower for persons in wheelchairs. See Figure 3.8.60., page 73.

Business and Personal Service

3.8.2.32. Business and Personal Service Occupancies

1) In a Group D *occupancy* with multiple *suites*, at least one *accessible* washroom, conforming to Sentence 3.8.2.3.(2), [p. 5] shall either

- a) be available to all *suites*, or
- b) be provided in each *suite* not having *access* to a washroom described in Clause (a).

Subsection 3.7.4. of Division B of the B.C. Building Code, requires buildings to be provided with toilets for the occupants and it must be taken that the word “occupants” includes clients and staff. Although conventional practice in many multi-tenant “storefront” type buildings has been to provide a single staff washroom in each tenant space and no “public” washroom, this does not conform to the Code (except in small retail) and at least a portion of the minimum number of required toilets should be available for clients and accessible to persons with disabilities. Staff washrooms must at least be easily retrofitted for accessibility if the need arises.

Sentence 3.8.2.32.(1) emphasizes that this washroom, whether located in each suite or tenancy, or in a separate location that is available to all suites or tenancies, is required to conform to the requirements of Subsection 3.8.3. [p. 17] Figure 3.8.4. [p. 16] illustrates an example of this requirement.

2) In offices, dental offices, medical offices, fire stations, police stations without detention quarters, radio stations, telephone exchanges and small tool and appliance rental and service premises, *access* shall be provided to areas to which the public is admitted.

3.8.2.33. Banks

- 1)** In banks and financial institutions, *access* shall be provided to
- a) every type of public *facility*,
 - b) at least one teller location conforming to Article 3.8.3.18. [p. 72], and
 - c) automated teller machines, night deposit boxes and similar services, where provided, which shall be installed to be usable by persons in wheelchairs.

Automatic teller machines must be located so that all functions, including visual readout screens, can be seen and used by persons in wheelchairs. As these machines are also used outside normal banking hours they must be accessible at these times.

3.8.2.34. Barbers and Hair Dressers

1) Where one or more hairdressing sinks are provided in barber shops, hairdressing shops and beauty parlours, *access* shall be provided to at least one hairdressing sink usable by persons in wheelchairs.

See comment under Sentence 3.8.2.7.(1) on page 7.

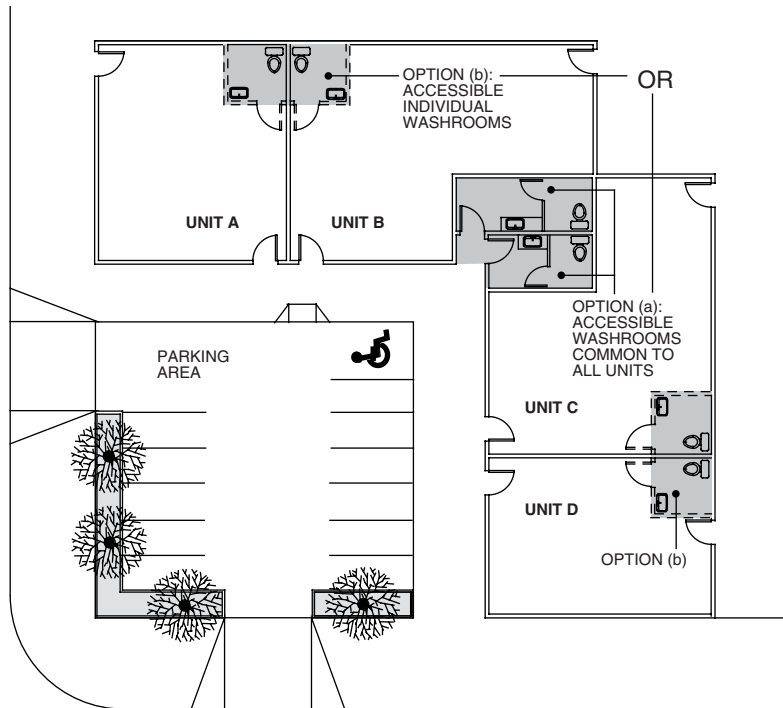

FIGURE 3.8.4. – Washrooms in Group D and E Occupancies

3.8.2.35. Laundry and Dry-Cleaning, Self-service

1) In self-service laundry and dry-cleaning premises, *access* shall be provided to at least one of each type of equipment installed for public use.

3.8.2.36. Mercantile Occupancies

- 1) In a Group E occupancy with multiple *suites*, at least one *accessible* washroom, conforming to Sentence 3.8.2.3.(2) [p. 5], shall either
- a) be available to all *suites*, or
 - b) be provided in each *suite* not having *access* to a washroom described in Clause (a).

Sentence 3.7.2.2.(16) in Division B of the B.C. Building Code permits the number of toilets in small retail occupancies to be determined based only on the number of staff. In many cases this will amount to only one washroom. On the basis that persons with disabilities could reasonably be expected to work there the washroom should at least be designed to be made accessible if needed.

2) In Group E *buildings*, *access* shall be provided to all public *facilities* and to areas to which the public is admitted.

Where fitting rooms are provided in a store an accessible fitting room is required. An enclosure about 1 500 mm by 1 500 mm is suggested. In a minimum sized space a fold down seat or loose chair without arms should be provided along with lower coat hooks and a handle on the inside of the out-swinging door. The latch should be operable by persons with limited use of their hands.

3.8.2.37. High Hazard Occupancies

1) <Group F, Division 1 occupancies> need not conform to the requirements of this Subsection.

3.8.2.38. Industrial Occupancies, Service Stations and Parking Garages

1) Except as provided in Sentences (2) and (3), in Group F, Division 2 and 3 *occupancies*, *access* shall be provided to all areas to which the public is admitted.

2) Service stations need not comply with Sentence 3.8.2.3.(1) [p. 4] except that for service stations with washrooms, regardless of service station floor area, the washrooms, shall conform to Sentence 3.8.2.3.(2). [p. 5]

This Sentence does not exempt convenience stores or retail auto parts stores attached to service stations and gas bars from the requirements for access. It was intended to exempt the small office area of the traditional service station.

3) In *storage garages access* need only be provided to *storeys* containing the *accessible* parking required by Article 3.8.3.4. [p. 25] or local bylaws.

3.8.2.39. Public Toilets

1) Public toilets located in highway rest areas, campgrounds, picnic grounds, parks, recreational vehicle parks, and mobile home parks need not comply with Sentence 3.8.2.3.(1) <except that the following shall be provided:>

- a) *access* from a roadway to at least one toilet *building* by means of a path of travel conforming to Article 3.8.3.2. [p. 17], and
- b) within the toilet *building*, toilet *facilities* conforming to Sentence 3.8.2.3.(2). [p. 5]

2) Where permanent bath or shower *facilities* are provided to serve areas described in Sentence (1), at least one bath or shower shall be *accessible* as described in Clause (1)(a) and conforming to Sentence 3.7.2.10.(10) or (11). [p. 63]

Washroom buildings are often erected in locations described in Sentence 3.8.2.39.(1). Persons with disabilities are mobile members of society and access to such facilities is necessary. Temporary and portable facilities should be accessible wherever possible.

3.8.3. Design Requirements**3.8.3.1. Application**

1) This Subsection applies to all *buildings* and parts of *buildings* that are required to be *accessible* under Subsection 3.8.2., <including without limitation> exterior paths and stairs within property lines from *streets*, parking areas and ancillary areas to at least one main entrance of these *buildings*.

3.8.3.2. Paths of travel

1) Walks to at least one main entrance and all ancillary areas that are required to be *accessible* shall

- a) be provided by means of a continuous plane not interrupted by steps or abrupt changes in level,
- b) have a permanent, firm and slip-resistant surface,

- c) have an uninterrupted width of not less than 1 500 mm, and a gradient not more than 1 in 20,

Walks must have an even surface and permit a continuous and uninterrupted path of travel. The minimum width requirement allows a wheelchair to pass an ambulatory person with ease.

It is important to note that the surface of a walk must be firm and even. Uneven surfaces can be hazardous not only to a person in a wheelchair but also to an ambulant person with a disability. When pre-cast units such as brick pavers, concrete slabs or tiles are used care should be taken to ensure that all joints are as flush as possible, with a maximum tolerance of 6 mm. (See Figure 3.8.5.) In all cases, the selected material must also be slip-resistant, which is of primary concern to an ambulant person with a disability. Cross slopes for drainage should be kept to an absolute minimum and where the walk is covered a cross slope should not be necessary.

- d) have a curb not less than 75 mm high where, in the absence of walls, railings, or other barriers on either or both sides of the walk, the vertical drop from the walk is more than 75 mm,
- e) not have gratings with openings that will permit the passage of a sphere more than 13 mm in diameter and have all elongated openings oriented approximately perpendicular to the direction of travel,

It is recommended that gratings be avoided on walks, especially at the bottom inclines or ramps, but if used should not present a hazard to persons using wheelchairs or other mobility aids. Elongated openings in line with the path of travel can trap the front wheels of wheelchairs and the small wheels of other mobility aids and openings larger than 13 mm can trap crutch and cane tips.

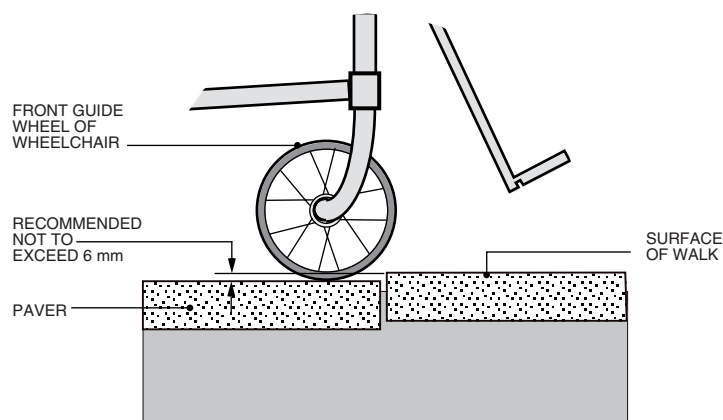

FIGURE 3.8.5. – Joints in Walks

- f) <where the path of travel is level and even with adjacent walking surfaces, have a texture, not less than 1 500 mm in width, that differs from the texture of the surrounding walking surfaces,>

Using brick pavers to delineate a walkway through a concrete plaza is an example of a difference in texture that aids persons with visual impairments. This would be applicable only to large open areas such as plazas and would not, for example, apply to a wide concrete walk with grass on each side. (See Figure 3.8.6.)

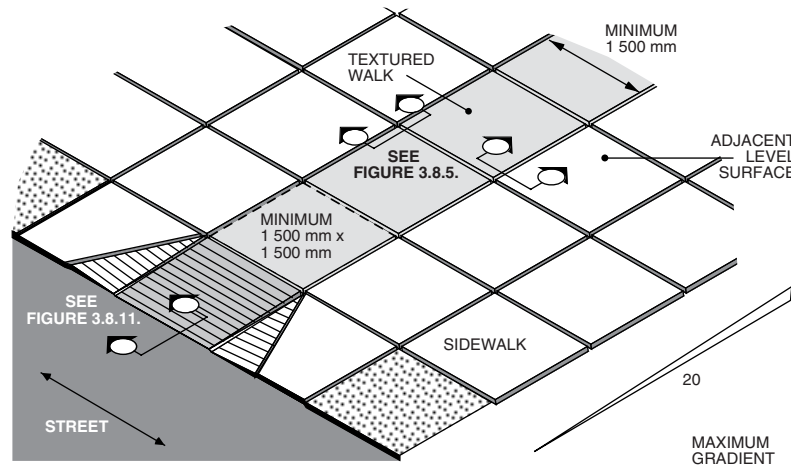

FIGURE 3.8.6. – Walks

- g) be free from obstructions for the full width of the walk to a height of not less than 1 980 mm, except that handrails are permitted to project not more than 100 mm from either or both sides into the clear area, and

The requirement to have an area free from obstructions (see Figure 3.8.7.) is primarily to aid persons with visual impairments. Examples of such obstructions are directional signs, tree branches and guy wires. The only permitted projections are handrails. Although a height greater than 1 980 mm is preferred, in order to maintain consistency this minimum height corresponds to the minimum headroom clearance for doorways.

- h) be designed as a ramp where the gradient of the walk is more than 1 in 20.

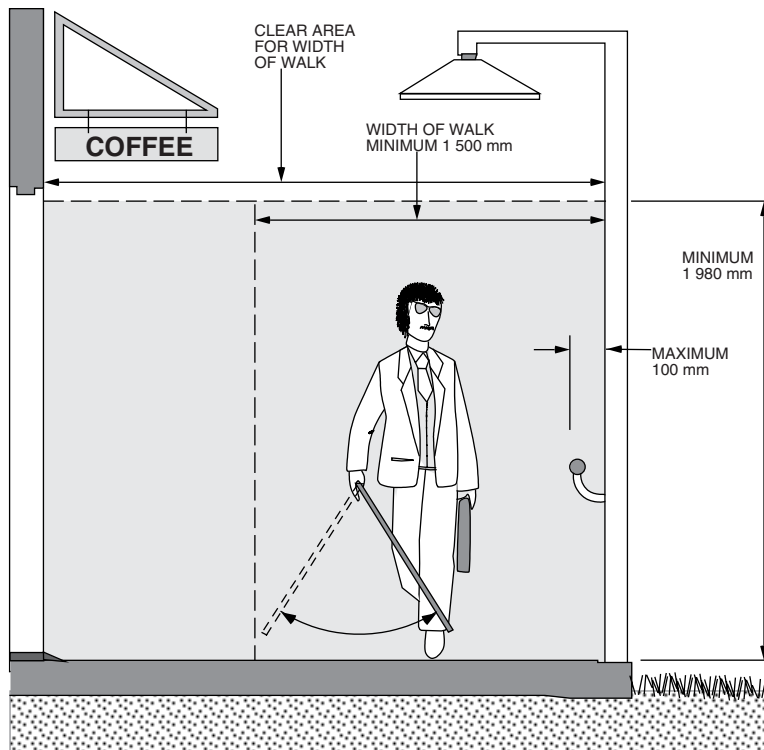

FIGURE 3.8.7. – Exterior Paths of Travel

3.8.3.3. Ramps

- 1) Where ramps are required to provide interior and exterior *access*, they shall
 - a) have an uninterrupted width of not less than 1 500 mm, except as permitted <by Sentences (4) and (6), and> Clause (7)(b),
 - b) have, where the vertical drop at the side of the ramp is more than 75 mm, either
 - i) a curb not less than 75 mm high, or
 - ii) walls, railings, or other barriers that extend to within 75 mm of the finished ramp surface,
 - c) be free from obstructions for the full width of the ramp to a height of not less than 1 980 mm, except that handrails, excluding those to ramps in Sentence (4) and Clause (7)(b), are permitted to project not more than 100 mm from either or both sides into the clear area,
 - d) be provided with an unobstructed, level area not less than 1 500 mm long by the width of the ramp, at the bottom and top ends, and at abrupt changes in direction,
 - e) have a level landing not less than 1 500 mm long by the width of the ramp at intervals conforming to Table 3.8.3.3., and
 - f) have gradients and maximum lengths conforming to Table 3.8.3.3. [p. 22]

Ramps are of obvious importance to persons in wheelchairs but can also be of benefit to elderly persons and people with strollers. However, some ambulant persons with disabilities can negotiate steps and for this reason, where a difference in elevation occurs, accessibility by both ramps and stairs should be considered. Figure 3.8.8. illustrates accessibility between elevations by both ramps and stairs.

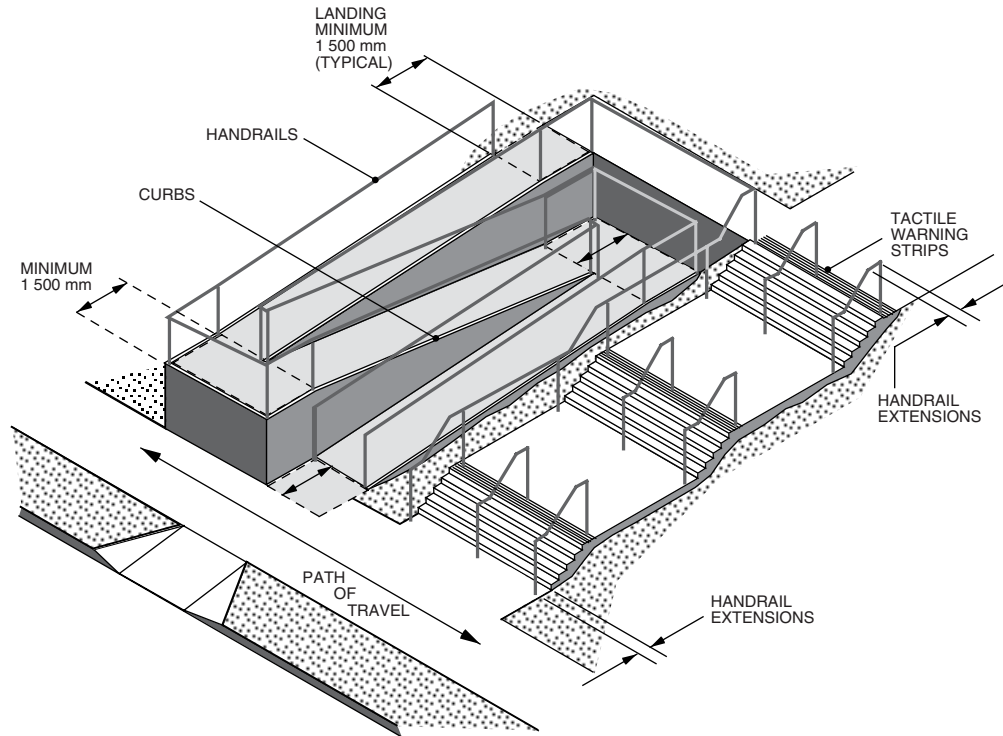

FIGURE 3.8.8. – Stair and Ramp Access

Although tactile warning strips are shown on each stair landing it is a matter of judgement whether or not the strips are necessary. Tactile warning should be provided once a landing becomes a walkway connecting two sets of steps.

Also note that handrail extensions have been incorporated without projecting into other paths of travel.

A level landing is required at the bottom and top ends of ramps to permit persons in wheelchairs to slow down and, if necessary, to stop. Landings are also necessary at changes in direction as it is extremely difficult to change the direction of a wheelchair when on a slope. Intermediate landings, which serve as resting points, are required at various intervals depending on the slope of the ramp.

Generally, the slope of the ramp should be as gentle as possible. The steeper the ramp, the greater the likelihood that persons in wheelchairs will require some form of assistance. Ramps with a slope of 1 in 12 can be difficult for many wheelchair users and ramps with slopes of 1 in 10 and 1 in 11 are extremely difficult and tiring for most persons in wheelchairs. For these reasons ramps steeper than 1 in 12 are restricted in their total length to a maximum of 6 m. It is not permissible to have a 1 in 10 ramp of 6 m, a landing and then another 1 in 10 or 1 in 11 ramp.

Curved ramps should be avoided unless the radius is extremely large. Most wheelchair users find it difficult negotiating a corner while ascending or descending a ramp. Landings, not curves, are required where ramps change direction.

Ramp surfaces must be slip-resistant. Consideration should be given to protecting ramps from snow and ice build-up and cross slopes should be avoided.

Very long ramps, such as would be needed to travel between storeys in a building, should also be avoided and may, due to their size or complexity, be more expensive than an elevating device.

In Clause 3.8.3.3.(1)(b) [p. 20] it is a requirement that when the vertical drop at the side of a ramp exceeds 75 mm a barrier is required. It must be either a 75 mm high curb or a barrier that extends down to a minimum of 75 mm from the finished ramp surface. This is to prevent the front guide wheel of a wheelchair from accidentally going over the edge of the ramp. Figure 3.8.9. shows some examples of protection at the sides of ramps.

- 2) Except as permitted < by > Sentences (3) and (5), handrails conforming to < Article 3.4.6.5. > [B.C. Building Code] shall be installed on both sides of ramps.
- 3) Where ramps described in Sentence (1) have a gradient not more than 1 in 12 and are not more than 2 m long, handrails are required on one side only.
- 4) Ramps with a gradient more than 1 in 12 shall have an uninterrupted width of 890 mm to 940 mm between handrails.

Table 3.8.3.3. Ramps
Forming Part of Article 3.8.3.3.

Gradient	Maximum Length	Maximum Landing Intervals	Handrails Required ⁽¹⁾
over 1 in 20 to 1 in 16	None	12 m	both sides ⁽²⁾
over 1 in 16 to 1 in 12	None	9 m	both sides ⁽²⁾
over 1 in 12 to 1 in 10 ⁽³⁾	6 m	—	both sides ⁽²⁾
over 1 in 10 to 1 in 8	600 mm	—	not required

Notes to Table 3.8.3.3.

- (1) See Sentence 3.8.3.3.(2)
- (2) See Sentence 3.8.3.3.(3)
- (3) See Sentence 3.8.3.3.(4)

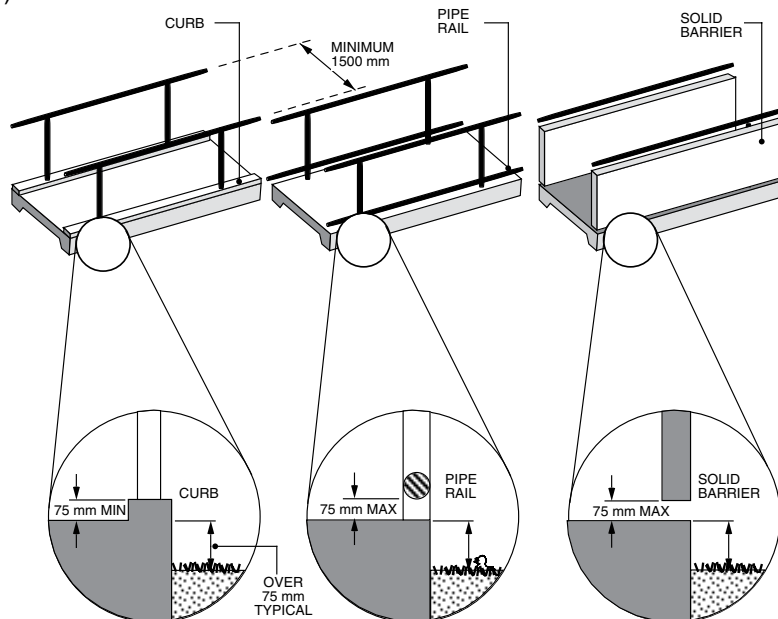

FIGURE 3.8.9. – Protection at Sides of Ramps

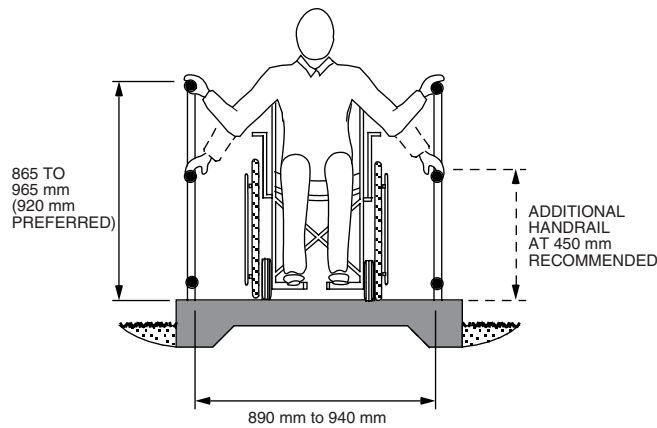

FIGURE 3.8.10. – Steep Ramp Section

Apart from very short ramps, handrails are required on both sides to allow persons with disabilities to use their good side.

Ramps with gradients of 1 in 10 to less than 1 in 12 are required to have handrails spaced $915 \text{ mm} \pm 25 \text{ mm}$ apart to allow persons in wheelchairs to pull themselves up with the aid of both handrails. It is also recommended that an additional handrail be located approximately 450 mm above the surface as an aid to persons in wheelchairs who may have a reach problem.

(See Figure 3.8.10.)

5) Handrails are not required to curb cut ramps.

Curb ramps, better known as curb cuts, (1 in 10 to 1 in 8) should not require handrails. They should be as gradual as possible and should not project out onto a road surface unless there is little or no vehicle traffic. A detectable difference in surface texture will assist in giving a secure foothold to ambulant persons with disabilities and, together with the change in plane, will also assist persons with visual impairments. Where a curb cut is in a path of travel the sides need to be sloped to avoid the problem of pedestrians, especially the visually impaired, unexpectedly stepping down into the cut.

If there is a drop at the toe of the curb cut, it shall be no more than 13 mm and sloped not greater than 45° to the horizontal. A level landing is not mandatory at the bottom of curb ramps. (See Figure 3.8.11.)

6) A ramp in a passageway up to and including 6 m in width shall be at least 915 mm wide between handrails.

7) Ramps in passageways over 6 m in width shall be either

- a) one ramp at least 1 500 mm wide, or
- b) two ramps each at least 915 mm wide between handrails.

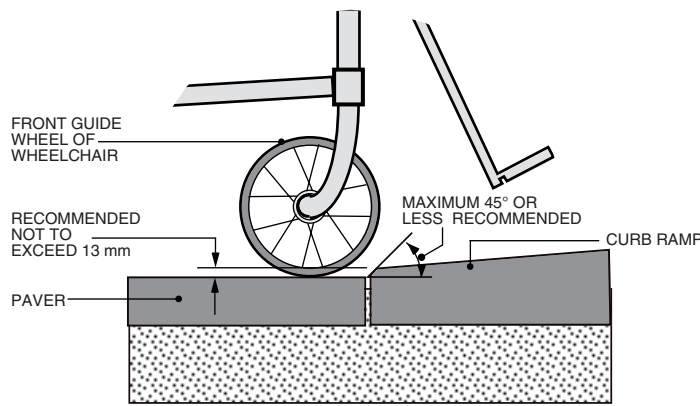

FIGURE 3.8.11. – Curb Ramp Detail

Where a definite change in level occurs in a passageway, the different levels must be connected by either a ramp or ramps, an elevator, an elevating device for persons with disabilities, or other means acceptable to the authority having jurisdiction.

Where ramps are used they must meet the minimum width requirements of Sentence 3.8.3.3.(7). [p. 23] Where a passageway is not more than 6 m in width, one ramp a minimum 915 mm wide is required. (See Figure 3.8.12.)

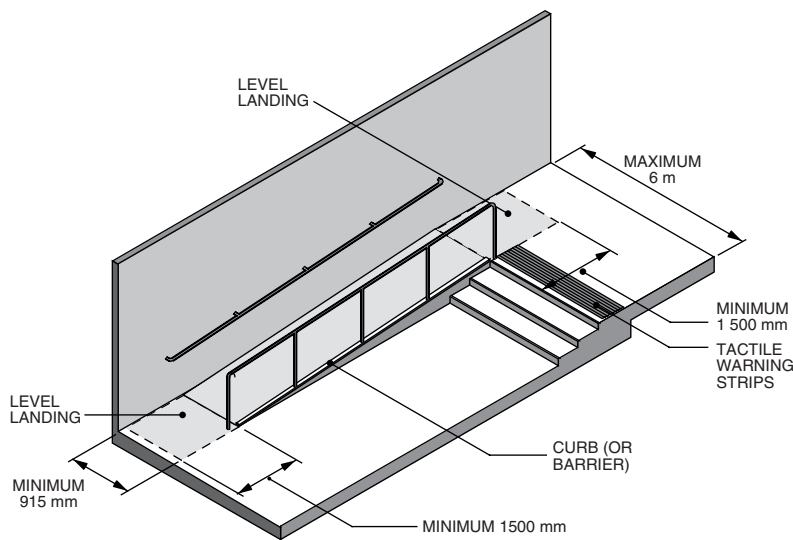

FIGURE 3.8.12. – Ramp in Passageways Up To 6 m Wide

Figure 3.8.13. shows a ramp at least 1 500 mm wide and, as an alternative, two ramps each at least 915 mm wide. These are generally intended for locations such as shopping malls, theatres, stadiums and other facilities where high pedestrian traffic is anticipated. Ramps are not required to be adjacent to a wall.

Handrails to ramps are described in Article 3.8.3.3. [p. 20]

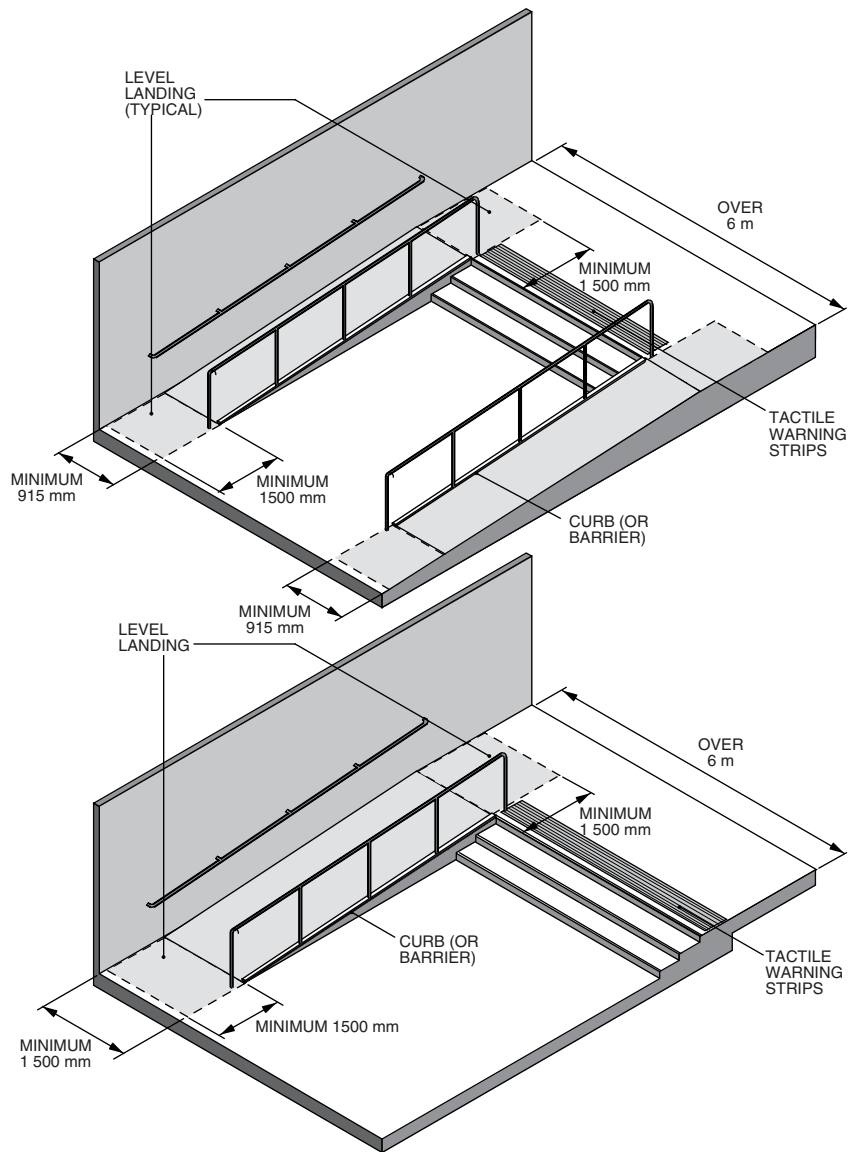

FIGURE 3.8.13. – Ramp in Passageways Over 6 m Wide

3.8.3.4. Parking Stalls for Persons with Disabilities

1) Where parking is provided, one parking stall for *persons with disabilities* shall be provided for each sleeping unit required to conform to Article 3.8.3.14. [p. 66] and for each viewing position required to conform to Article 3.8.3.15. [p. 69] and shall

- a) be at least 3 700 mm wide,
- b) have a firm, slip-resistant and level surface,
- c) be located close, and be *accessible*, to an entrance conforming to Article 3.8.3.5. [p. 27], and
- d) be clearly identified as being solely for the use of *persons with disabilities*.

2) In all other *occupancies*, where more than 50 parking stalls are provided, parking stalls for *persons with disabilities* shall be provided in the ratio of 1 for every 100 or part thereof.

Parking stalls for persons with disabilities should be located close to accessible entrances or in a central location when a parking lot serves several buildings. In large parking lots or parkades directions to these parking stalls should be given as close to the points of entry as possible, and in all instances such stalls should be clearly identified as being for use only by persons with disabilities. Careful consideration should be given to locating parking stalls so as to minimize the need for persons in wheelchairs to travel behind other cars since wheelchairs are difficult to see from inside a vehicle, especially in a rear view mirror.

The required width of 3.7 m for a parking stall for persons with disabilities includes about 1 200 mm for entering and leaving the vehicle. Figure 3.8.14., which also shows the sequence of transferring from a car to a wheelchair, illustrates how the 1 200 mm wheelchair access space may serve more than one parking stall. The wheelchair access spaces should be on the same surface as the vehicle space and be clearly marked to ensure the proper parking of vehicles. (See comment under Sentence 3.8.3.12.(1)) [p. 51] Consideration should be given to providing some spaces 4.7 m wide for side loading vans which are becoming increasingly popular for drivers with disabilities. Spaces for rear loading vans should also be considered.

The requirement for the parking stall(s) to be level cannot be overemphasized. The vehicle/wheelchair transfer is awkward enough without the added complication of a slope which can make the vehicle’s door difficult to open or close and cause the wheelchair to roll away.

The number of parking stalls for persons with disabilities required by the code is fairly easy to determine but in instances where parking stalls may be used by the same people over an extended period of time, such as by staff and students at a college, it is recommended that the number of stalls be calculated to suit the specific need. Some buildings such as medical clinics may need more accessible parking stalls than the minimum in this Article and some jurisdictions may have other requirements in their zoning/parking bylaws.

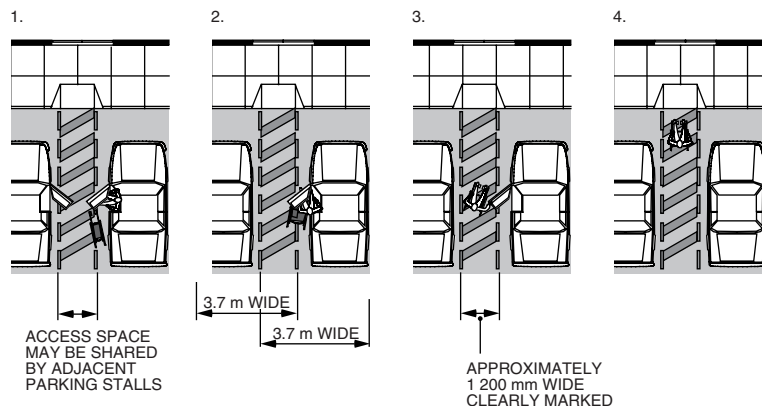

FIGURE 3.8.14. – Parking Stalls

3.8.3.5. Main Entrances

1) A *building* shall have at least one main entrance conforming to Sentences 3.3.1.13.(10) to (12). [p. 31]

At least one of the main or primary entrances to a building is required to be accessible and usable by persons with disabilities. This entrance would be one which is normally used by the public or regular occupants. A service or 'trades' entrance cannot be accepted as a main entrance unless it is the only entrance to a building or facility such as may occur at a factory or garage.

2) Where *<access is not provided to any main entrance,>* a sign (see Sentence 3.8.3.12.(3)) [p. 51] shall be installed as far ahead of any wheelchair obstruction as is practical so as to indicate clearly the location of the *accessible* main entrance.

From a street or parking area it is possible, due to design features or landscaping, that the main entrance may appear accessible but is, in fact, inaccessible. Sentence 3.8.3.5.(2) requires that a sign be provided in such a location as to eliminate the possibility of persons in wheelchairs traveling up to such an entrance only to find it inaccessible.

3) *Access* shall be provided from every *accessible* main entrance to all parts of the *building* required *<by Subsection 3.8.2. to be accessible.>*

Limitations on projections into exit widths, tactile warnings which assist persons with visual impairments, and stair requirements which assist many ambulant persons with other disabilities are examples of access requirements which are required throughout a building, even in areas not accessible to wheelchairs. Sentence 3.8.3.5.(3) refers to all persons with disabilities and not just persons in wheelchairs. Even though access for persons in wheelchairs may not be provided to a particular part of a building, requirements that provide for ambulant persons with disabilities are still required.

4) *<Power operation, that functions for passage in both directions, shall be provided for all doors in an accessible path of travel at the exterior accessible entrances to*

- a) a hotel,
- b) a Group B, Division 2 *major occupancy*,
- c) any of the following is more than 500 m² in area:
 - i) an *assembly occupancy*,
 - ii) a *business and personal services occupancy*,
 - iii) a *care occupancy*, and
 - iv) a *mercantile occupancy.>*

Although fully automatic doors activated by motion detectors are preferred, power operated doors activated by accessible switches are considered to meet the requirement for power operated doors. To be considered as accessible an operating switch must be operable with a closed fist and be easily reached by both persons in wheelchairs and persons walking. The switch must be located so that the person using it is not in the way of the opening door.

Automatic or power operated doors are also of great assistance to the able bodied of all ages. Parents pushing strollers, shoppers pushing carts or carrying parcels or small children and the elderly who have difficulty opening self-closing doors all appreciate automatic or power operated doors.

Clause (c) is intended to require automatic doors on individual occupancies of more than 500 m². It is not intended, for example, to require automatic doors on each 250 m² store in a 1 000 m² building.

5) If a walkway or pedestrian bridge connects two *accessible storeys* in different *buildings*, the path of travel from one *storey* to the other *storey* by means of the walkway or bridge shall be *accessible*.

Where the connected storeys of the two buildings are at different elevations there may need to be a ramp or lift at at least one end of the bridge to allow access to it or the bridge will need to have a gradient not more than that allowed for ramps.

Interior Access

3.3.1.9. Corridors

3) Except as permitted by Sentence (4), obstructions located within 1 980 mm of the floor shall not project more than 100 mm horizontally into an *exit* passageway, a *public corridor*, a corridor used by the public or a corridor serving classrooms or patients' sleeping rooms in a manner that would create a hazard for a person with a visual disability traveling adjacent to the walls.

4) The horizontal projection of an obstruction referred to in Sentence (3) is permitted to be more than 100 mm provided the clearance between the obstruction and the floor is less than 680 mm.

The cane used by blind or visually impaired persons can normally detect obstructions that are within 680 mm of the floor. Obstructions above this height would not normally be detected and can, therefore, create a hazard if they project more than 100 mm into the path of travel. Figure 3.8.15. illustrates the requirement for a clear area in a passageway.

It is preferred that passageways be no less than 1 220 mm wide to allow an ambulant person to pass a person in a wheelchair. A minimum clear width of 1 500 mm is necessary to allow two persons in wheelchairs to pass one another.

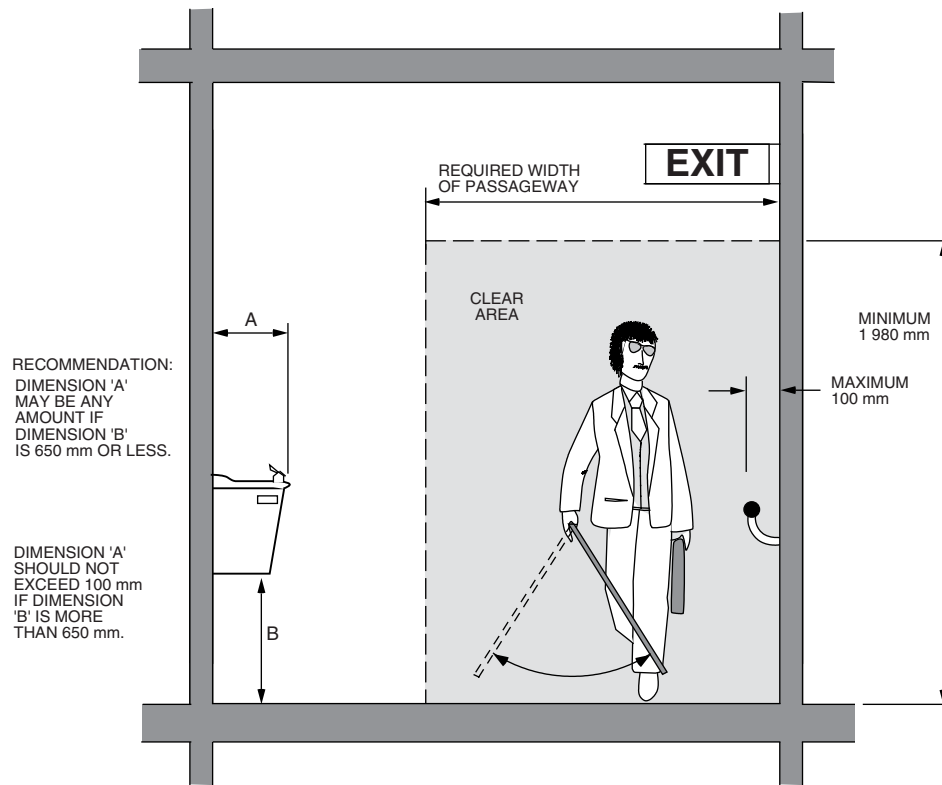

FIGURE 3.8.15. – Interior Passageway

Figures 3.8.16. through 3.8.19. demonstrate the minimum dimensions needed to allow a person in a wheelchair to manoeuvre between or around obstructions.

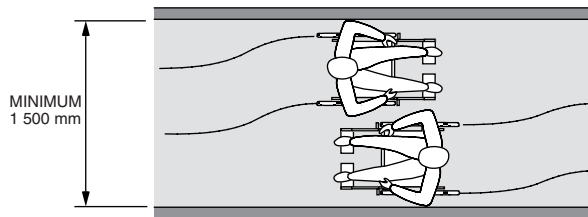

FIGURE 3.8.16. – Corridor Width

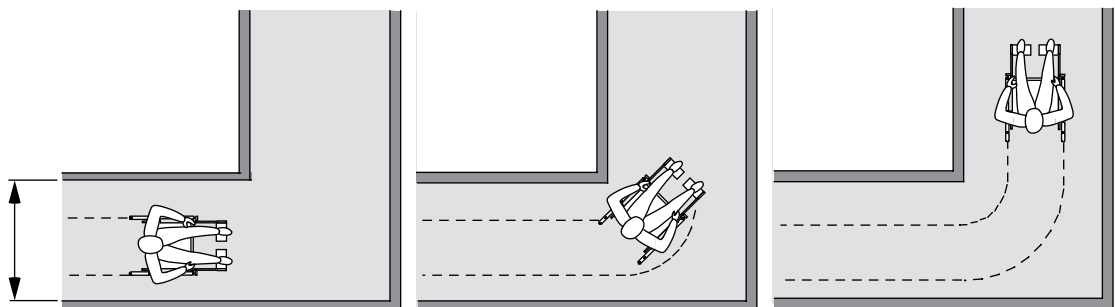

FIGURE 3.8.17. – 90° Turn

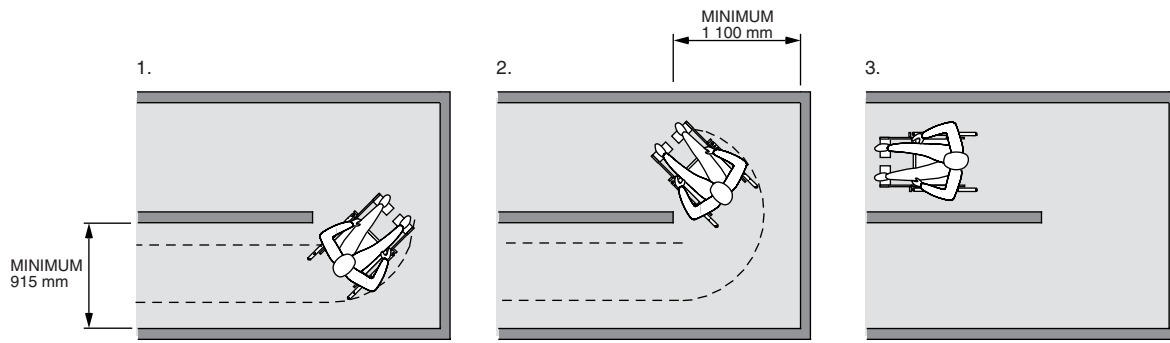

FIGURE 3.8.18. – 180° Turn

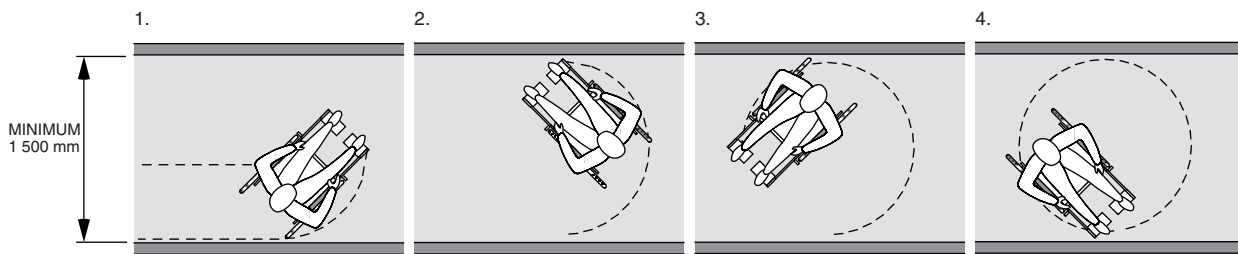

FIGURE 3.8.19. – 360° Turn

3.8.3.6. Interior Passageways

1) In passageways, abrupt changes in floor level shall not exceed 13 mm, except where ramps conforming to Sentences 3.8.3.3.(6) and (7) [p. 23] are provided.

The number of abrupt changes in level should be kept to a minimum and where they do occur they must not exceed 13 mm. Figure 3.8.20. gives examples of how changes in level might occur. In Detail 'A' the 13 mm dimension is measured on the leading edge of the strip which is acceptable provided that the slope of the strip is kept to a minimum, preferably no steeper than 1 in 20.

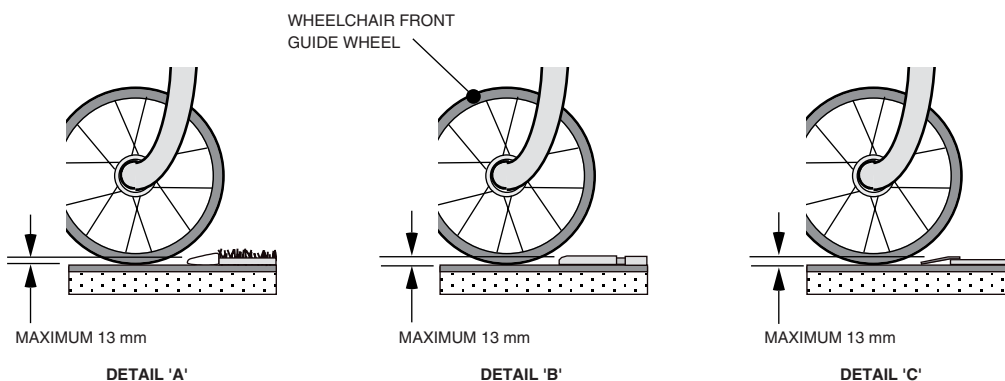

FIGURE 3.8.20. – Abrupt Changes in Floor Level

3.3.1.13. Doors and Door Hardware

1) <Except as required by Article 3.3.3.4.,> a door that opens into or is located within a *public corridor* or other *facility* that provides *access to exit* from a *suite* shall

- a) provide a clear opening of not less than 800 mm if there is only one door leaf,

Doors in the open position must provide a clear passage of 800 mm which allows for persons in wheelchairs to safely pass through. (See Figure 3.8.21.) Although it is possible for a person in a wheelchair to negotiate a narrower opening, greater precision is necessary on their part. Also, if an opening less than 800 mm wide is approached from any direction other than straight on, a greater amount of manoeuvring is required.

- b) in a doorway with multiple leaves, have the active leaf providing a clear opening of not less than 800 mm,

If both leaves of a two leaf doorway are less than 800 mm a person in a wheelchair must attempt to open both doors simultaneously which is all but impossible.

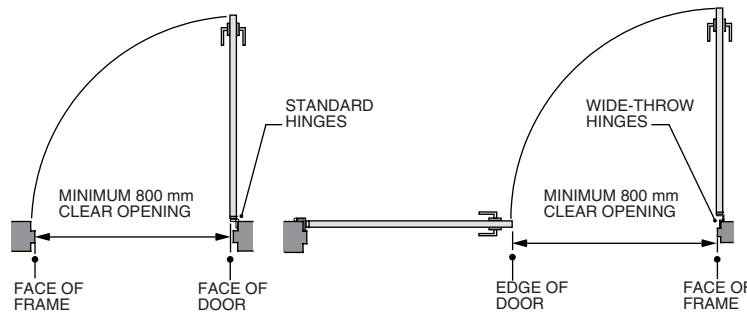

FIGURE 3.8.21. – Clear Opening at Doors

10) Door assemblies providing *access* shall

- a) conform to Clauses (1)(a) and (b),
- b) have a clear and level area
 - i) when the door swing is towards this area, of not less than 1 500 mm long by a width equal to the door assembly width plus not less than 600 mm clear space beside the latching jamb of the door,
 - ii) when the door swing is away from this area, not less than 1 200 mm long by a width equal to the door assembly width plus not less than 300 mm clear space beside the latching jamb of the door,

When a door swings towards a person in a wheelchair, a clear and level space is required on the latch side of the door to allow manoeuvring of the wheelchair while opening the door. (See Figure 3.8.22.) A clear and level space is also required when the door swing is away from the person in a wheelchair although the side clearance requirement is less. (See Figure 3.8.23.)

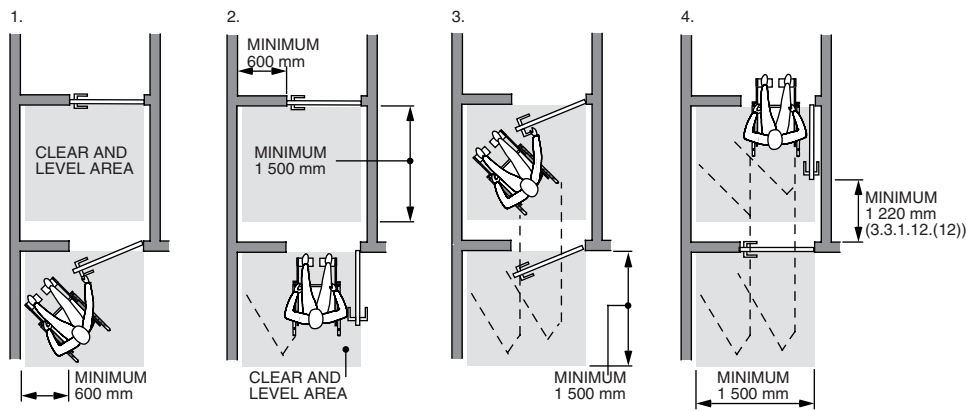

FIGURE 3.8.22. – Door Swing Towards Wheelchair and Vestibule Clearance

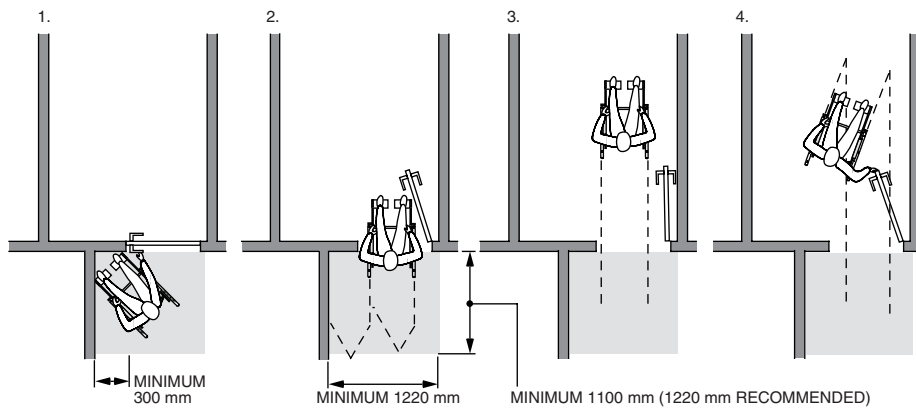

FIGURE 3.8.23. – Door Swing Away From Wheelchair

- iii) for power operated sliding doors or power operated doors swinging away from <this> area, not less than 1 100 mm long by the width of the door assembly, and
- iv) for power operated doors swinging into <this> area, not less than 1 100 mm long plus the arc of the door swing by the width of the door assembly,

Door Handles

- c) be operable by devices which do not require tight grasping, or twisting of the wrist, as the only means of operation,

For persons with impaired hand and/or wrist functions, door knobs do not provide for an adequate grip, and on doors which are latched, render a door virtually impossible to open. Push-pull mechanisms which do not require grasping are acceptable but lever type handles are the best solution for most doors. As most doors in buildings “provide access” for persons with disabilities there are few doors where traditional knobs are acceptable. Lever handles are more convenient for everybody, not just a necessity for many persons with disabilities. Levers should return to the door surface or be otherwise designed so as not to catch clothing or other objects. (See Figure 3.8.24.)

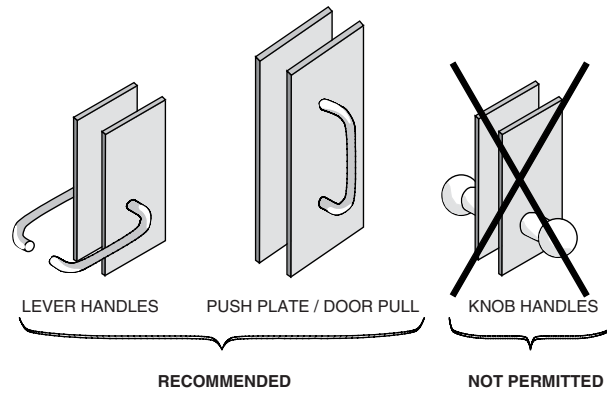

FIGURE 3.8.24. – Door Hardware

- d) operate when a force of not more than 38 N for exterior doors and not more than 22 N for interior doors is applied at the handle, push plate or latch-releasing device, except for locations where greater pressures are required to ensure proper *building* function, and

The effort needed to overcome the resistance of a door closer must be as low as practical in order for persons with disabilities to pass through doors with reasonable ease. The higher resistance permitted for exterior doors recognizes the need for some exterior doors to close against wind forces and building pressurization. All door closers should offer as little resistance to opening as possible. The 38 N and 22 N forces are maximum.

- e) if equipped with a closer, have a closing period of not less than 3 seconds measured from the door in an open position of 70° to the doorway to a point 75 mm from the closed position measured from the leading edge of the latch side of the door.

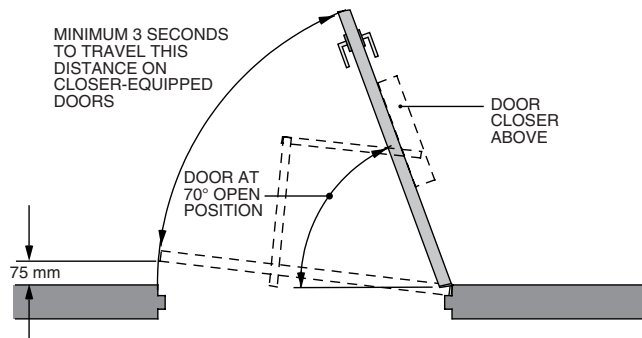

FIGURE 3.8.25. – Closing Time of Door

11) In doorways, where thresholds are not flush with the floor, the difference in level shall be not more than 13 mm and shall be bevelled.

The maximum height for thresholds is 13 mm. (See comment under Sentence 3.8.3.6.). [p. 30] The reason for this is that, at doorways, raised thresholds can be a hazard to ambulant persons with disabilities and to the elderly. Also, they are particularly inconvenient to persons in wheelchairs because complex manoeuvring is necessary to both open a door, especially if equipped with a closer, and, at the same time, negotiate a wheelchair over a threshold.

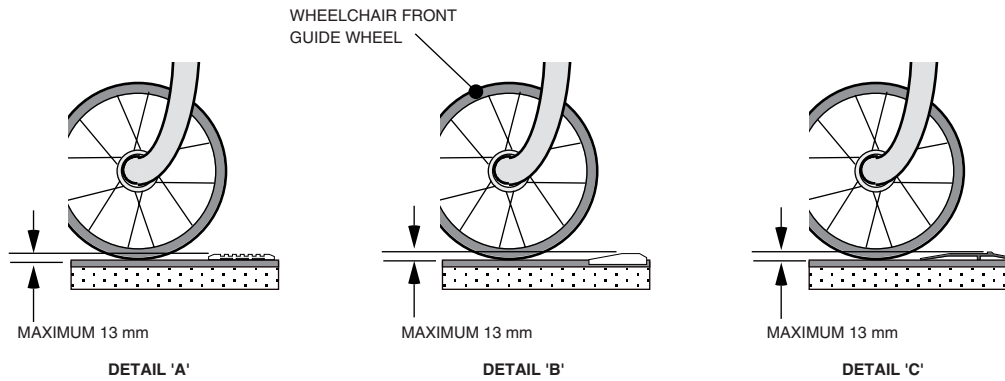

FIGURE 3.8.26. – Thresholds

12) Doors which are installed in series shall be separated by a space not less than 1 200 mm plus the width of any door swinging into the separating space. (See also Clauses 3.2.8.5.(1)(a) and 3.3.5.7.(4)(a), B.C. Building Code)

See Figure 3.8.22. on page 31.

3.8.3.7. Public Aisles

1) The effective width between any two structures or fixtures in public aisles in merchandising establishments and exhibition *facilities* shall be not less than 1 100 mm.

Although 1 100 mm is the required minimum width between any two structures or fixtures it is recommended that, particularly in merchandising establishments, this be increased to at least 1 500 mm to allow an ambulant person with a shopping cart to safely pass a person in a wheelchair. (See Figure 3.8.27.)

3.8.3.8. Turnstiles

1) Where turnstiles, controlled checkout lanes or other restricted passageways are constructed to control the flow of pedestrian traffic, at least one such facility shall be

- a) <not less than 800 mm wide and>
- b) clearly marked for use by persons in wheelchairs.

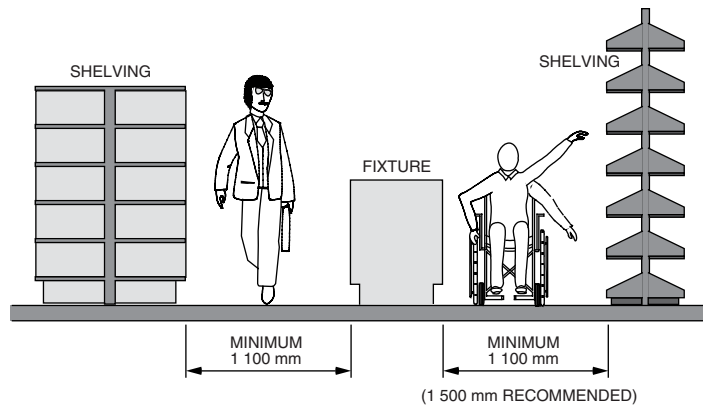

FIGURE 3.8.27. – Aisles

Turnstiles cannot be used by persons in wheelchairs and can be hazardous to ambulant persons who use canes or crutches. In addition, the configuration and width of checkout lanes can be such that they cannot be used by persons in wheelchairs.

Where turnstiles are used it is preferred that an immediately adjacent gate be provided as shown in Figure 3.8.28. A standard passage door in close proximity to the turnstiles would also be acceptable provided the door was clearly identified as being for use by persons with disabilities.

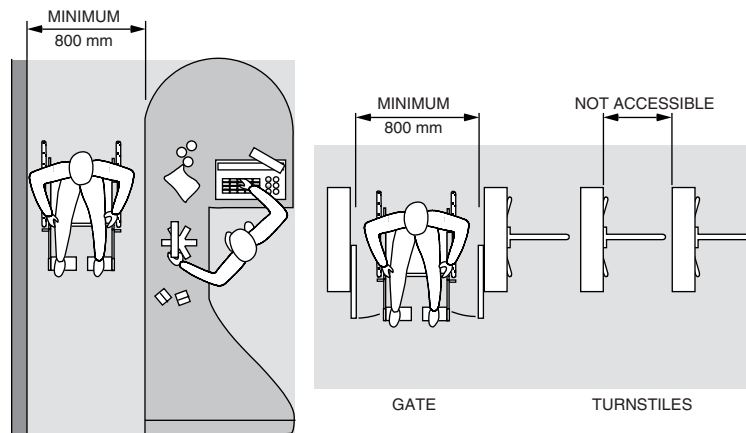

FIGURE 3.8.28. – Restricted Passageways

3.8.3.9. Food Service Lines

- 1) Where permanent food service lines are provided they shall
 - a) be not less than 920 mm wide and
 - b) have not less than 920 mm wide entry and egress points.

Figure 3.8.29. illustrates the requirements of Article 3.8.3.9. It is recommended that the top of the tray rail be no more than 915 mm above the floor.

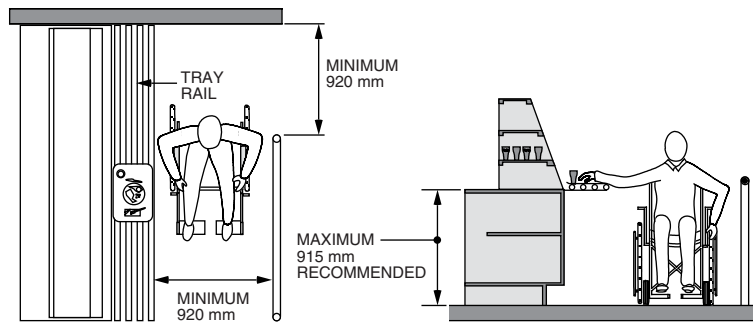

FIGURE 3.8.29. – Food Service Lines

Vertical Access

Although access may be required to a particular storey or area of a building, it is not a requirement that such access must be provided by a passenger elevator. The method used to provide access is at the discretion of the designer with a qualification being that whichever method or methods are used they must conform to the requirements for access. Many elevating devices for persons with disabilities, when installed in public places, are locked and must be operated by someone other than the user. Unless such lifts are under continuous supervision by an operator they are all but useless to persons with disabilities.

Sentence 3.5.2.1.(3) requires elevators providing access to conform with Appendix E of the CSA Elevator Code, B44.

Article 3.5.4.1. of the B.C. Building Code requires at least one elevator in each building provided with elevators to be large enough to accommodate an ambulance stretcher. This should not be construed to mean that a wheelchair lift must accommodate a stretcher.

3.8.3.10. Floor levels

1) Except for floors and levels specifically excluded in Subsection 3.8.2., [p. 3] floors and levels at different elevations shall be connected by

- <a) a ramp conforming to Article 3.8.3.3.,
- b) an elevator conforming to Appendix E of CAN/CSA-B44, “Safety Code for Elevators,”
- c) an elevating device for persons with disabilities conforming to CAN/CSA-B355, “Lifts for Persons with Physical Disabilities,” or
- d) other means acceptable to the *authority having jurisdiction*.>

Figure 3.8.30. illustrates some of the methods that may be used to provide access to and between floors. A ramp is not shown because they are generally not a practical method of providing storey to storey access.

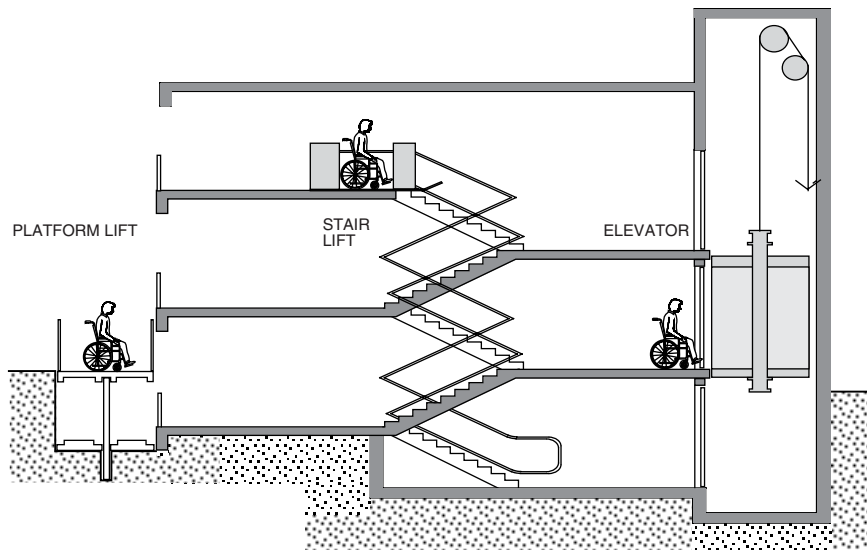

FIGURE 3.8.30. – Access Between Floors

3.5.2.1. Elevators, Escalators and Dumbwaiters

3) Passenger elevators shall conform to Appendix E of ASME A17.1/CSA-B44, “Safety Code for Elevators and Escalators.”

All passenger elevators are required to be accessible. The following requirements are quoted from Appendix E of CSA-B44-04, “Safety Code for Elevators.”

“The elevator shall be automatic and be provided with a two-way automatic-maintaining levelling device to maintain the floor level to +/- 13 mm.”

doors

“The minimum clear width for elevator doors shall be 910 mm.”

“Doors shall be provided with a door-reopening device that will function to stop and reopen a car door and an adjacent hoistway door to at least 910 mm, in case the car door is obstructed while closing. This reopening device shall also be capable of sensing an object or person in the path of a closing door at a nominal 125 mm ± 25 mm and 735 mm ± 25 mm above the floor without requiring contact for activation.”

“Door-reopening devices shall remain effective for a period of not less than 20 s.”

“From the time the doors start to open, a minimum period of 4 s shall elapse before the doors start to close, if it is a hall call and 3 s if it is a car call. This time may be reduced after operation of the door close button.”

car size

“The minimum distance between the walls or between wall and door, excluding return panels, shall be not less than 1725 × 1370 mm. The minimum distance from wall to return panel shall be not less than 1300 mm. On cars designed to allow for the turning of a wheelchair, the minimum clear distance between walls or between wall and door, excluding return panels, shall be not less than 1725 × 1370 mm.”

The required internal car dimensions allow persons in wheelchairs to enter, turn through 180° with moderate ease, and exit from the elevator. The width and depth dimensions, which are interchangeable, should not prevent other elevator car shapes from being permitted, provided it can be shown that accessibility and manoeuvrability for persons in wheelchairs is maintained.

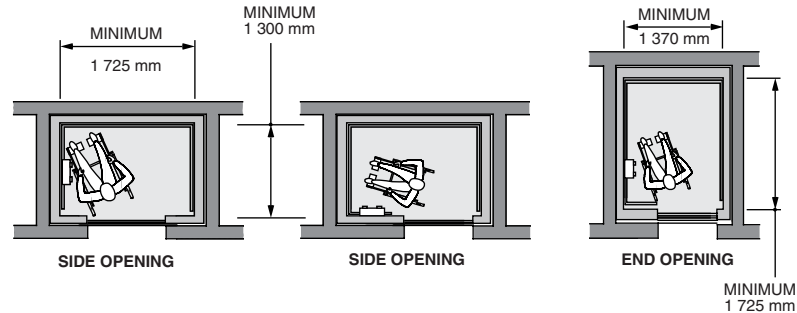

FIGURE 3.8.31. – Elevator Car Size and Operating Panel Location

Controls

“Controls shall be readily accessible from a wheelchair upon entering an elevator.”

The location of the car operating panel is dependent on the dimension of the front return panel. Where the front return panel is less than 470 mm the car operating panel is required to be located on the side wall of the car which is, in fact, the most convenient location for persons who use wheelchairs. When the car operating panel is located on the side wall it is recommended that it be a minimum of 250 mm from the front return panel. When the panel is mounted on the front return it should be as far as possible from the side wall or it will be very difficult to reach.

Each of the various arrangements shown in Figure 3.8.31. allow persons in wheelchairs to enter the elevator car and readily use the car operating panel.

“Emergency controls and door-operating buttons shall be grouped together at the bottom of the control panel. The centreline of the alarm button and the emergency-stop switch shall be a nominal not less than 890 mm from the floor. The centreline of the highest floor button shall be no higher than 1370 mm from the floor. Other controls may be located where it is convenient.”

Although configurations other than as shown in Figure 3.8.32. are acceptable it is preferred that floor buttons always be arranged vertically to give a direct functional correlation to the direction of travel.

This height approaches the upper reach limit of persons in wheelchairs with unlimited use of their arms. As many people in wheelchairs do not have full use of their arms every effort should be made to keep the highest controls in the area of 1 100 mm above the floor.

“Floor registration buttons shall be a minimum 19 mm in size and they may be raised, flush, or recessed. The depth of flush or recessed buttons when they are being operated shall not exceed 10 mm.”

Buttons are required to have a “minimum dimension of 19 mm,” but it is not mandatory that they be round. Flush or recessed buttons should be carefully designed to be usable by persons with little or no use of their fingers.

“Arabic numerals shall be adjacent on the left of the floor buttons on a contrasting colour background. Markings shall be a minimum of 16 mm high and raised a minimum of 0.75 mm. Permanently attached plates are acceptable. Where the call buttons are mechanical, the raised markings may be on the buttons.”

Having a “contrasting colour background” for markings is not intended to restrict the material or finish of the elevator car and car control panel. For example, it is acceptable to have flush contrasting numbers or letters located on the buttons and, in addition, raised markings to the side which would then not be required to be in a colour that contrasts with the background. The sizes of letters or numbers on the buttons may be reduced slightly to suit the size of the buttons.

Many persons who are blind cannot read Braille, but they can readily identify raised markings and this is the required method of identification. To have both Braille and raised markings is not recommended as this tends to clutter the control panel, possibly creating confusion for the users.

“Symbols as indicated in Clause 3.6.1.10 shall be used to assist in readily identifying essential controls.”

“The markings shall have a minimum height of

- (a) 5 mm for lettering; and
- (b) 10 mm for symbols, unless otherwise specified.”

Some of the symbols referred to above are shown below in Figure 3.8.32.

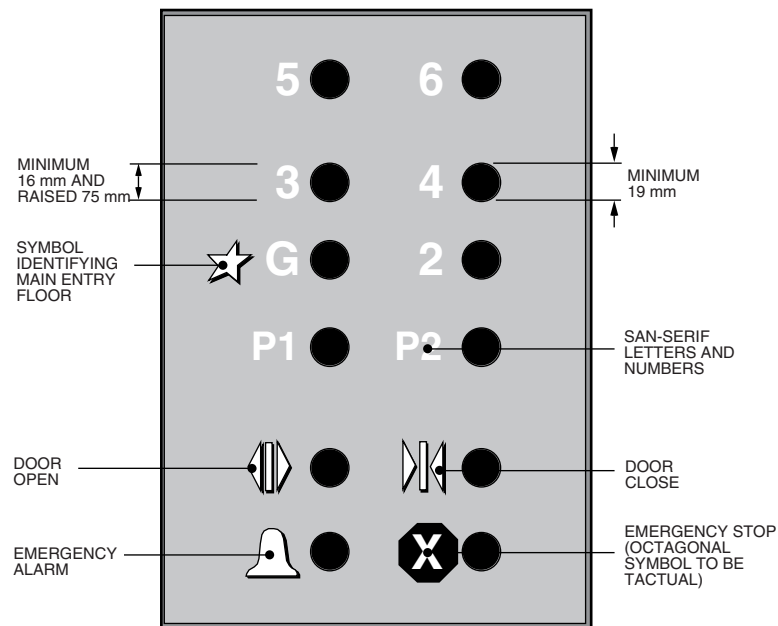

FIGURE 3.8.32. – Elevator Car Operating Panel

“Visual and momentary audible indication shall be provided to show each call registered and visual indication shall be extinguished when the call is answered.”

“An indicator shall be provided in the car to show the position of the car in the hoistway, by illuminating the indication corresponding to the landing at which the car is stopped or passing. Indication characters shall be on a contrasting colour background and a minimum of 16 mm in height.”

“The telephone shall be located a maximum of 1 220 mm from the floor with a minimum cord length of 900 mm.”

Emergency telephone cabinets should be mounted at an accessible height, not down near the floor or above the operating panel.

“The international symbol for telephones shall be located on the telephone cabinet in a contrasting colour. The symbol shall be a minimum of 38 mm high and raised a minimum of 0.75 mm. Permanently attached plates are acceptable. Telephones shall be equipped with a receiver that generates a magnetic field in the area of the receiver cap and the telephone shall have a volume control and shall comply with CSA Standard T515.”

“The floor shall have a firm and slip-resistant surface that permits easy movement of wheelchairs.”

A soft under-cushion in combination with a carpet having a thick and long pile makes manoeuvring for persons in wheelchairs particularly difficult. Carpets should be well fitted to the floor.

“Handrails shall be provided on all non-access walls 800 to 920 mm with a space of 35 - 45 mm between the rails and wall.”

Persons who have stability problems depend a great deal upon handrails in elevators. Although not a requirement, it is preferred that handrails in elevators be graspable.

“The illumination at the car controls and landing sill shall be not less than 100 lx.”

“The centreline of the hall call buttons shall be 1070 ± 25 mm above the floor. Buttons shall be a minimum of 20 mm in size, and shall be mounted one above the other.”

“Visual indication shall be provided to show each call that is registered and that is extinguished when the call is answered.”

“Hall or in-car lanterns shall be provided. The centreline of the fixture shall be a minimum of 1830 mm above the floor. An audible signal shall be provided when the elevator stops at the landing. Visual elements shall be a minimum of 60 mm in the smallest direction.”

“Arabic numerals a minimum of 50 mm high and raised at least 0.75 mm shall be placed on both sides of the door jambs, with the centre line at 1500 ± 25 mm above the floor to identify the floor level.”

Figures 3.8.33. and 3.8.34. illustrate the requirements contained in Appendix E of CSA-B44 but should not prevent other designs, systems and technological developments from being permitted. For example, the illustrations show side-opening doors but centre-opening doors are also acceptable. Car shapes other than that shown may also be permitted.

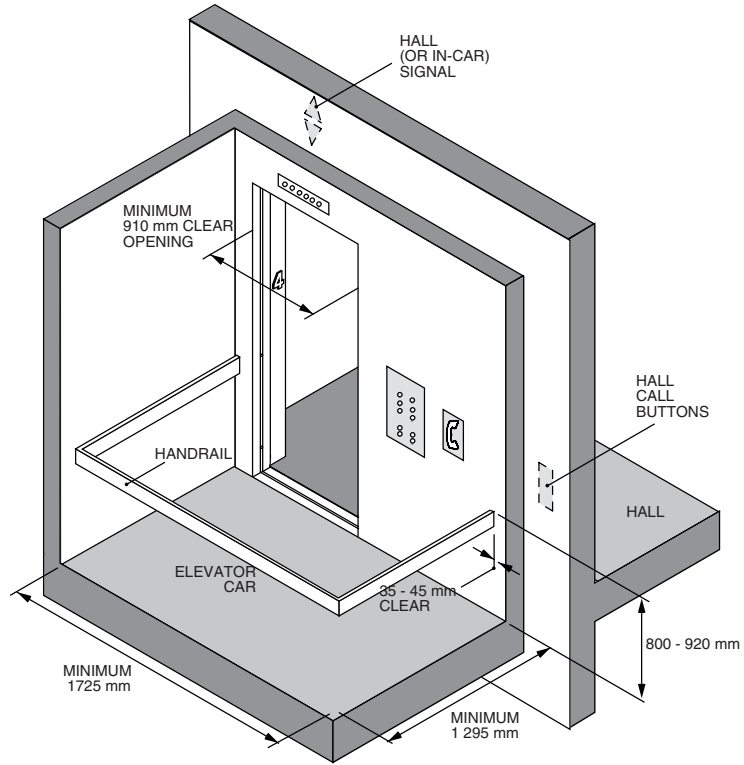

FIGURE 3.8.33. – Elevator Car Dimensions

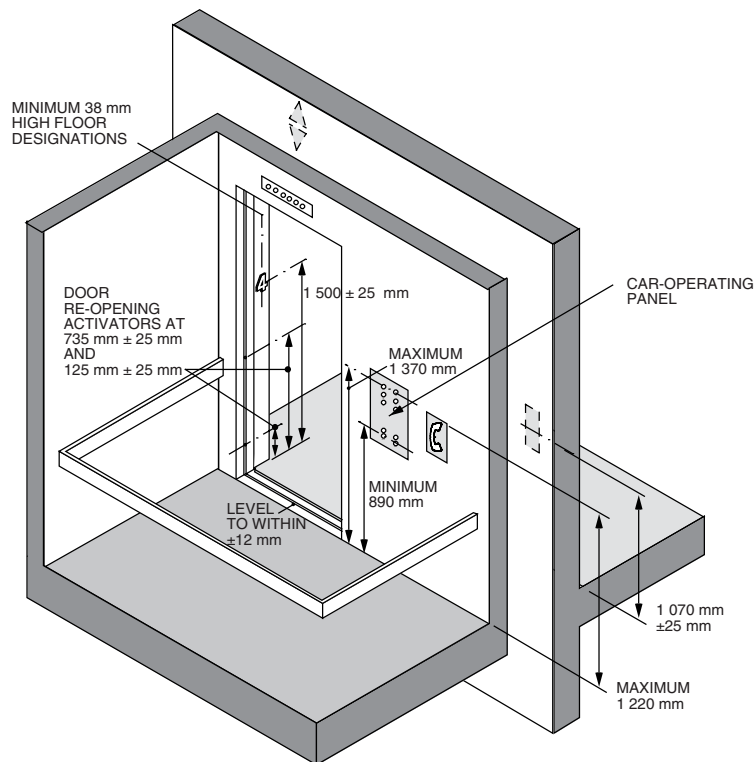

FIGURE 3.8.34. – Elevator Car Controls

3.4.6.1. Slip-Resistance of Ramps and Stairs

- 1) The surface of ramps, and landings and treads
 - a) shall have a finish that is slip-resistant, and

The following table is a general guide for slip resistance of materials based on coefficient of friction testing.

Slip Resistance of Floor and Tread Finishes		
Slip Resistance		
Material	Dry and Unpolished	Wet
Carpet	very good	good
Clay tiles	good	poor to fair
Clay tiles, textured finish or non-slip granules	very good	good
Concrete	good	poor to fair
Concrete, textured finish or non-slip aggregate	very good	good
Linoleum	good	poor to fair
Rubber, sheet or tiles	very good	very poor
Sheet vinyl	good	poor to fair
Sheet vinyl, non-slip granules	very good	good
Terrazzo	good	poor to fair
Vinyl asbestos tiles	good	fair

Note: Slip-resistance of very good and good is acceptable.
Slip-resistance of fair and poor is not acceptable

- b) if accessible to the public, shall have either a colour contrast or a distinctive pattern, readily visible from both directions of travel, to demarcate the leading edge of the tread and the leading edge of the landing, as well as the beginning and end of a ramp.

Making the nosings a sharply contrasting colour to the remainder of the tread is the preferred and easiest method to make them “readily apparent from both directions of travel.” However, careful material selection and lighting design can permit the use of a single material and colour. A mock-up of a few treads and risers using proposed materials and representative lighting can establish whether or not there is an inherent difference between one nosing and the next.

3.4.6.8. Treads and Risers

(See A-9.8.4. in Appendix A.)

- 1) Except as permitted for *dwelling units* and by Sentence 3.4.7.5.(1) for fire escapes, steps for stairs shall have a run of not less than 280 mm between successive steps.
- 2) Steps for stairs referred to in Sentence (1) shall

- a) have a rise between successive treads not less than 125 mm and not more than 180 mm,
 - b) have a closed riser, and
 - <c) have
 - i) a riser with a rakeback of not more than 38 mm, or
 - ii) the underside of the nosing with an angle of not less than 60 degrees from the horizontal.>
- 8) The top of the nosing of stair treads shall**
- a) except as permitted in Sentence (10), have either a radius or a bevel between 6 mm and 10 mm in horizontal dimension,
 - b) have no abrupt angles on the underside, and
 - c) not project more than 38 mm.

Open risers are hazardous to ambulant persons with disabilities. People who wear leg braces or prosthetic devices need a solid riser to guide the foot up over the riser to the next step and, to maintain balance, those who use canes or crutches place them against the riser of the step above the one they are on.

Where projecting risers are used, they must meet the above requirements, as nosings with sharp or abrupt angles prevent the sliding foot action described above and can cause tripping.

Figure 3.8.35. illustrates the tread and riser requirement of Article 3.4.6.7. It also shows, in Details 'C' and 'D', two tread and riser designs which do not meet the requirements of Article 3.4.6.7. The whole of Article 3.4.6.7., Sentences (1) to (5), in the B.C. Building Code should be reviewed for the general design requirements for stairs.

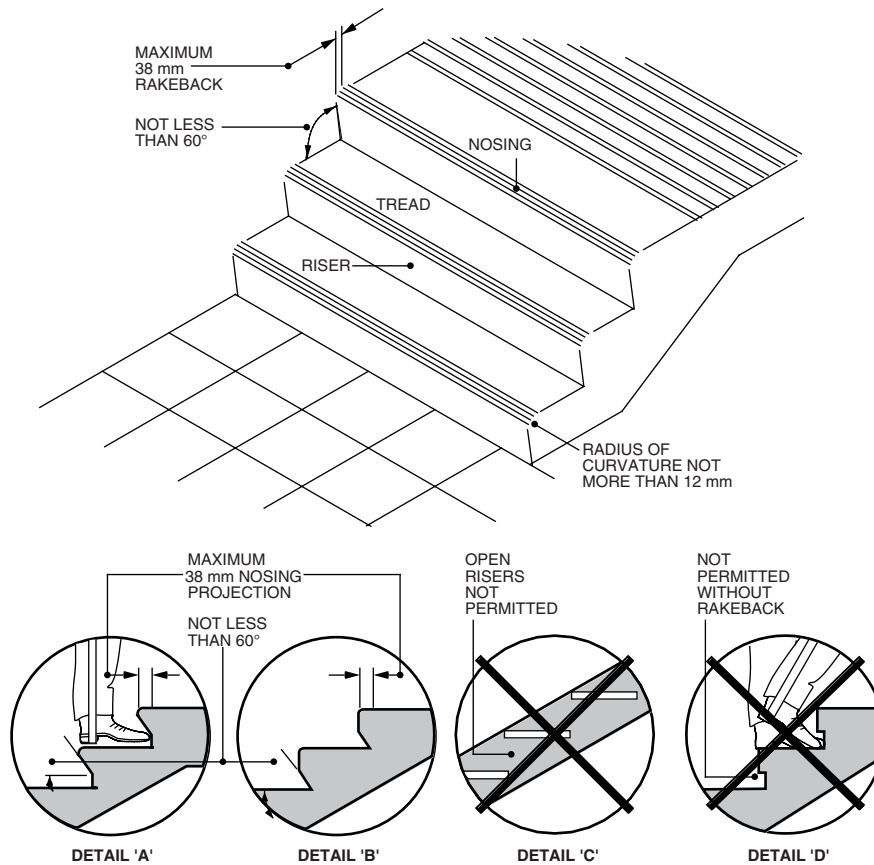

FIGURE 3.8.22. – Stair Design

3.4.6.5. Handrails

1) A stairway shall have a handrail on at least one side, but if it is 1 100 mm or more wide, it shall have handrails on both sides.

3) Handrails shall be continuously graspable along their entire length and shall have

- a) a circular cross-section with an outside diameter not less than 30 mm and not more than 43 mm, or
- b) a non-circular cross-section with a graspable portion that has a perimeter not less than 100 mm and not more than 125 mm and whose largest cross-sectional dimension is not more than 45 mm.

Handrails must be of such a design that they can be easily grasped and provide a firm yet comfortable grip so that the hand can slide along the rail without meeting obstructions. A circular section with an outside diameter of 30 to 43 mm provides a satisfactory grip for most people. Handrails are extremely important features and as such graspability cannot be overemphasized. Figure 3.8.36. shows examples of acceptable and unacceptable handrails.

4) <The height of> handrails on stairs and ramps shall be measured vertically from <the top of the handrail to>

- a) <a straight line drawn tangent to the tread nosings of the stair served by the handrail (see A-9.8.7.4. in Appendix A), or>
- b) the surface of the ramp, <floor or landing served by the handrail.>

- 5)** <Except as provided in Sentences (6) and (7), the height of handrails on stairs and ramps shall be
- a) not less than 865 mm, and
 - b) not more than 965 mm.

Although a height tolerance from 865 mm to 965 mm measured to the top of the rail is permitted for handrails, studies have shown that higher handrail heights are generally preferred, particularly for elderly persons, and that 920 mm is the optimum height.

- 8)** Except where interrupted by doorways or newels at changes in direction, at least one handrail shall be continuous throughout the length of the stairway or ramp, including landings.

Blind or visually-impaired persons rely on handrails to guide them on stairways. A continuous handrail assists them in negotiating stairs at changes in direction. It is preferable to provide a continuous handrail, not interrupted by newels, on the inside of the stair because this provides the shortest path of travel.

- 9)** Handrails shall be terminated in a manner which will not obstruct pedestrian travel or create a hazard.

- 10)** At least one handrail at the side of a stairway or ramp shall extend horizontally not less than 300 mm beyond the top and bottom of the stairway or ramp.

Handrail extensions at the top and bottom of stairs and ramps are important. They provide support to those persons who, because of a disability, have difficulty in negotiating stairs. They also provide tactile cues for persons with visual impairments.

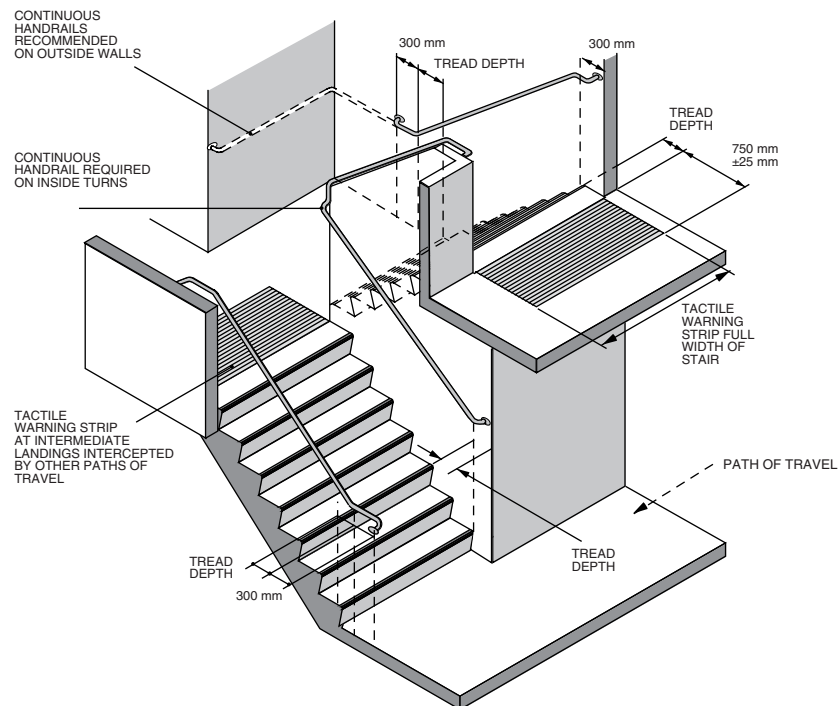

FIGURE 3.8.37. – Handrails and Tactile Warning Strips

Although extensions are preferred at the top and bottom of all stairs and ramps they are not required where they would project into another path of travel. However, with careful design, handrail extensions can be incorporated into most stair and ramp designs, whether or not a wall or guard exists. (See Figure 3.8.37. and also Figure 3.8.8. [p. 21])

Although the Code only requires the handrail to extend 300 mm beyond the riser there is an advantage to first extending the handrail one tread width past the bottom riser. This brings the handrail to the same height above the floor as it is above the stair treads and assists persons who need the handrail to ascend the stairs.

- 11)** The clearance between a handrail and any surface behind it shall be not less than
- 50 mm, or
 - 60 mm if the surface behind the handrail is rough or abrasive.

Figure 3.8.38. illustrates the clearance requirements described in Sentence (8) and suggests two methods of dealing with railings adjacent to rough surface.

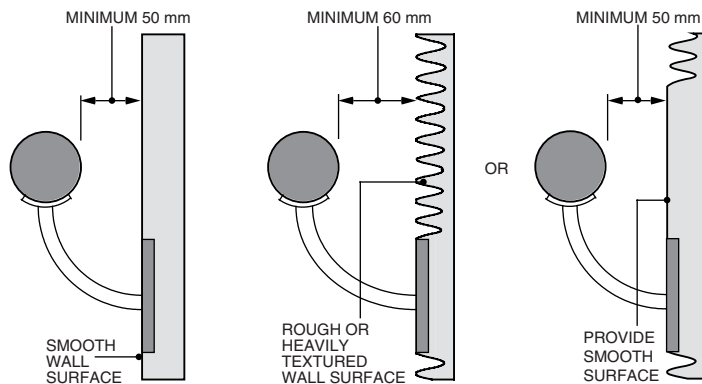

FIGURE 3.8.38. – Handrail Clearances

Warning Systems

3.8.3.11. Tactile Warning Systems

1) To assist persons with a visual impairment, tactile warning strips conforming to Sentence (2) shall be provided at the top of a stairway and at intermediate landings intercepted by other paths of travel.

2) <Tactile warning strips required by Sentence (1) shall measure 725 mm to 775 mm by the full width of the stair and be

- located > one tread width back from the top riser,
- slip-resistant,
- durable,
- not more than 3 mm above or below the surrounding floor surface,
- detectable <when walked upon> as being different from the surrounding flooring, and
- in a contrasting colour to the surrounding flooring. (See Appendix A.)

Tactile warning strips are required for stairs that provide access but are required only at specific locations in the stairway. In an open stairway (exit stairways are normally enclosed) the tactile warning strips would be required at the top and at any intermediate landing on the stairway that meets with another path of travel or circulation route. Tactile warning should also be provided when landings become long enough that a person with visual impairment would assume the stair has ended and they are now on a walkway or in a corridor. Stairs intended primarily for emergency egress do not require tactile warning systems.

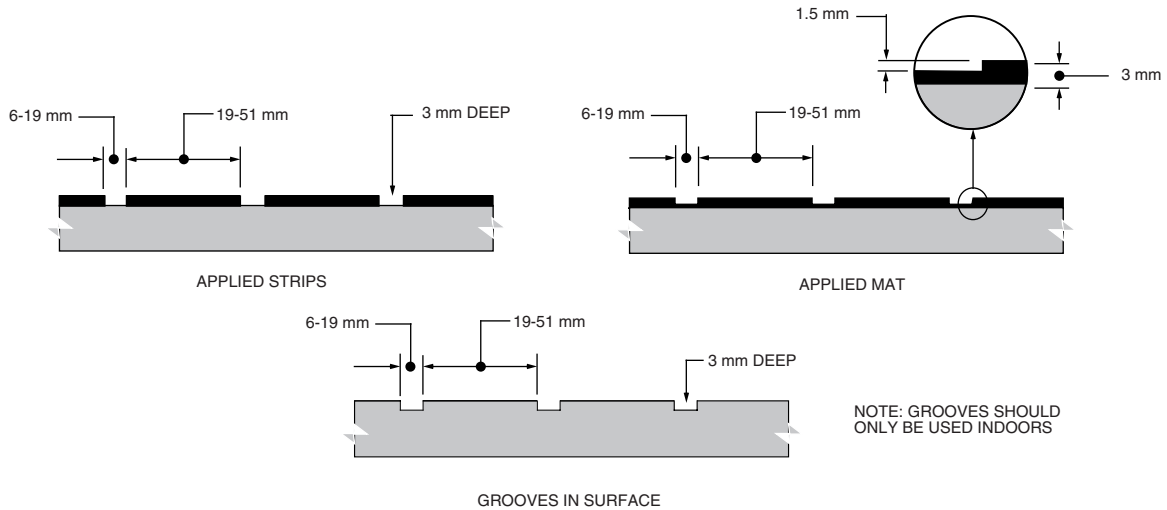

FIGURE 3.8.39. – Tactile Warning Strips

Situations other than those described here will inevitably occur and the question to be asked is whether or not these stairs are in such a location as to necessitate a tactile warning to persons with a visual impairment. Once persons with a visual impairment enter a particular stair system they exercise caution until they leave it, therefore tactile warning strips are not required at every landing, only at those landings where people can enter the stair system. (See Figure 3.8.37.) Figure 3.8.39. illustrates three acceptable tactile warning strip designs.

3.2.4.20. Visual Signals

3) Except as provided in Sentence (6), to assist persons with a hearing impairment, a visual warning system conforming to Sentences (4) and (5) shall be installed in locations described in Articles 3.8.2.27. to 3.8.2.31. [p. 12 - 14]

Audible emergency warnings, i.e., the fire alarm or the smoke alarm, may not be communicated to persons with hearing impairments. The required visual warning system can alert persons with hearing impairments to an emergency condition even when they are sleeping.

It is also recommended that visual signals conforming to this Article be installed in occupancies or parts of occupancies where persons with hearing impairments may be employed.

4) The visual warning system required by Sentence (6) and Sentences (4) and (5) shall consist of strobe lights supervised, activated, and powered by means of the fire alarm

system (supervised by the fire alarm system means up to, but not including, the strobe lights), and be connected to, activated by, and powered by, the sounding of the *smoke alarm* and

The warning system is required to be supervised (built-in, continuous, automatic monitoring of the alarm system to detect and notify of system faults) only up to the strobe lights, i.e., the wiring to the strobe lights. This compares to the requirement in referenced standards that only the wiring to fire alarm bells, and not the actual bells, are required to be supervised.

- a) have a luminous intensity of not less than 2 candelas and produce between 1 and 3 flashes per second,

Candelas are a measurement of luminous intensity.

- b) have a clear or white translucent lens,
- c) have the word “FIRE” clearly visible on the lens or attached nameplate,
- d) be installed in each
 - i) bedroom,
 - ii) room closed off from the living area by a door except a bathroom, and
 - iii) living area or hallway serving the living area, and
- e) be located in conformance with the installation requirements for visual signal devices in CAN/ULC-S524, “Installation of Fire Alarm Systems.”

5) When the strobe lights described in Sentences (4) and (7) are activated by the *smoke alarm*, a separate small indicator light shall be activated and shall be located

- a) immediately adjacent to the strobe lights and clearly identified as “SMOKE,” or
- b) on the *smoke alarm*, or immediately adjacent to the *smoke alarm*.

It is important that the occupants of a suite know if the flashing of the strobe light has been activated by the building’s fire alarm system or by the smoke alarm located in their suite. This information is conveyed by a small indicator light which must be located so as not to confuse to the occupant. The indicator light can be immediately adjacent to every strobe light required in the suite and identified with a sign reading “SMOKE”, it can be on the smoke alarm, i.e., integral with the unit, or it can be immediately adjacent to the smoke alarm with no separate identification being necessary.

Regardless of which method is used to indicate an emergency condition it is recommended that building management provide staff training on this and other warning systems and that occupants, particularly in hotels, motels and the like, are fully informed of the locations and functions of such systems.

Figure 3.8.40. illustrates a residential suite and shows locations for strobe lights that meet Code requirements and their connection to both the fire alarm system (when a fire alarm system is provided) and the suite’s smoke alarm.

Suites in apartment buildings designed as senior citizens’ residences need only be provided with special strobe light outlet boxes and cover plates (see Sentence 3.2.4.20.(7) [p. 50]) whereas strobe lights are required in other occupancies.

6) When a fire alarm system is not provided in *occupancies* required by Subsection 3.8.2. to have a warning system, *smoke alarms* required by Sentence 3.2.4.21.(1) and Article 9.10.19.1. in such *occupancies* shall be provided with strobe lights, in locations described in Articles 3.8.2.27. to 3.8.2.31., <that>

- a) <are> connected to, and activated by, the sounding of the *smoke alarm*,
- b) have a luminous intensity of not less than 2 candelas and produce between 1 and 3 flashes per second,
- c) have a clear or white translucent lens,
- d) have the word “SMOKE” clearly visible on the lens or attached nameplate,
- e) <are> installed in each
 - i) bedroom,
 - ii) room closed off from the living area by a door except a bathroom, and
 - iii) living area or hallway serving the living area, and
- f) be located not less than 2 100 mm above the floor on a wall or ceiling in a location that will maximize effectiveness.

Occupancies described in Articles 3.8.2.27. to 3.8.2.31. may not be required to have a fire alarm system. Where smoke alarms are required in these occupancies, strobe lights connected to them must be provided. In dwelling units in apartment buildings designed as senior citizens’ residences the suites need only be provided with special outlet boxes and cover plates. (See Sentence 3.8.2.27.(3), page 13) Figure 3.8.40. illustrates a dwelling unit showing locations of strobe lights, or special outlet boxes and cover plates, and their connection to the dwelling’s smoke alarm.

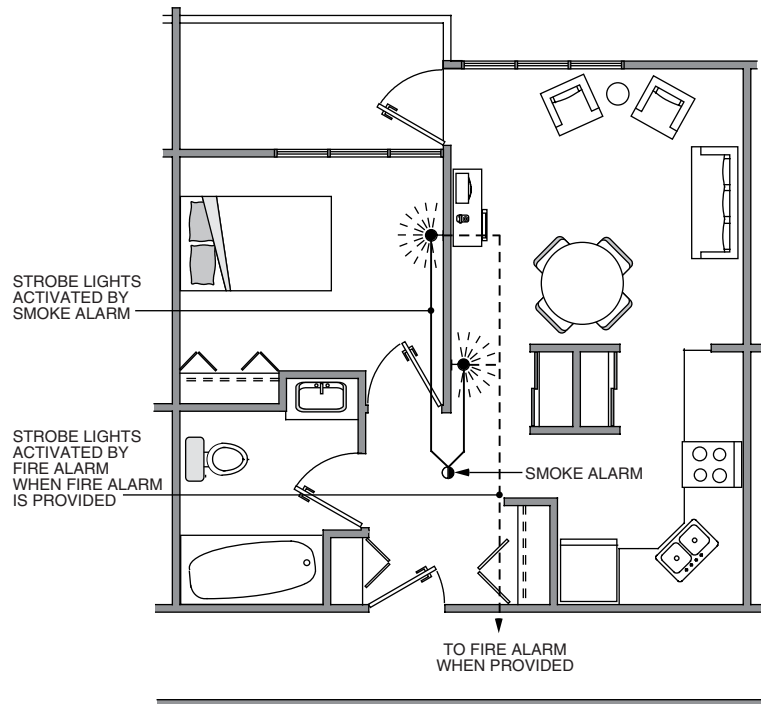

FIGURE 3.8.40. – Strobe Lights

7) The special outlet boxes <and> cover plates required by Sentence 3.8.2.27.(3) shall <be>

- a) designed and wired specifically to allow strobe lights conforming to Clause (6)(a) above
 - i) to operate as required by Sentence (4) for a fire alarm system where a fire alarm system is provided, and
 - ii) to be connected to, and activated by, the sounding of the *smoke alarm* (see also Sentence (5)),
- b) permanently identified as “FIRE — Strobe Light Connection Only,”
- c) <installed in each
 - i) bedroom,
 - ii) room closed off from the living area by a door except a bathroom, and
 - iii) living area or hallway serving the living area, and
- d) be located not less than 2 100 mm above the floor on a wall or ceiling in a location that will maximize effectiveness.>

Although Sentence (6) only requires outlet boxes which will permit strobe lights to be hard-wired into the alarm system as needed it may be less costly in the long term, and more convenient, to provide receptacles for plug-in strobe lights. Hard-wiring a strobe light constitutes an alteration to the fire alarm system and requires both a properly qualified technician and a system verification each time a strobe light is connected, relocated or removed. Also see comment under Sentences (4) and (5) above.

8) For the purpose of providing power to the strobe lights that may be connected to the outlets described in Sentence (7), it shall be assumed that the total special outlets for at least <20 per cent of the *dwelling units in the building*> are in use.

In apartment buildings designed as senior citizens’ residences it may be extremely difficult to anticipate which suites, and how many of them, would be required to have strobe lights to serve the needs of tenants with hearing impairments. Although every suite is required to be wired for strobe lights, to avoid excessive loading on the fire alarm power supply, the load necessary to serve 20 percent of the suites in the building is all that need be used in the sizing of the power supply. It is recommended that a higher percentage be used wherever possible as hearing deficits are common with seniors and the percentage of the population with hearing deficits seems to be steadily increasing.

3.8.3.12. Directional Signs

1) Except as permitted <by> Sentence (2), signs conforming to Sentence (3) shall be installed to provide adequate identification of, and direction to,

- a) an alternate main entrance as required by Sentence 3.8.3.5.(2), [p. 27]
- b) alternate *access* routes,
- c) *accessible* viewing positions,
- d) *accessible* refreshment facilities,

- e) *accessible* washrooms and toilet rooms,
- f) levels of a multi-level parking structure containing parking stalls for *persons with disabilities*,
- g) parking stalls conforming to Article 3.8.3.4., [p. 25] and

Parking stalls should be clearly identified by signs mounted 1.5 m above the ground which makes it easier for a disabled person to locate them. Painting the international symbol of accessibility on the pavement (approximately 1 m square) helps to discourage misuse of the parking stall but, as it can easily be obscured by dirt or snow when outdoors, this should be used only in addition to the raised sign. Signs should be located at the entrance(s) to parking structures to indicate on what levels and/or in what areas the accessible parking stalls are located. (See comment under Article 3.8.3.4., page 25)

- h) *accessible* checkout lanes.

2) Sentence (1) need not apply to *buildings* or parts of *buildings* where the degree of *accessibility* provided is such as to make these signs unnecessary.

If a building or part of a building is totally accessible to persons with disabilities the need for signs may be significantly reduced. For example, if all washroom facilities in a building are accessible there would be no need to give direction to each one.

3) Signs required by Sentence (1) shall

- a) be located so as to be easily read and understood,
- b) be located so as to be seen by a person in a wheelchair,
- c) have a glare-free surface,
- d) for parking spaces, be 1 500 mm above the ground measured to the bottom of the sign,

See comment under Clause 3.8.3.12.(1)(g) on this page.

- e) have characters with a stroke width-to-height ratio of from 1:6 to 1:10 and a character width-to-height ratio of from 3:5 to 1:1 using only Arabic numerals and sans-serif letters,
- f) have characters and symbols in colours that contrast highly with their backgrounds, and

Persons with visual impairments have difficulty reading traditional signs. The required character dimensions, when used with a matte finish and a high contrast of 85% to 95% (between the colour of the character and its background), make very readable signs. Good choices of colours which provide high contrast are blue or black backgrounds with white letters and yellow background with black letters. Exit signs are best with white letters on a red background. Figure 3.8.41. illustrates the character proportion requirements and the high contrast requirement between the character and its background.

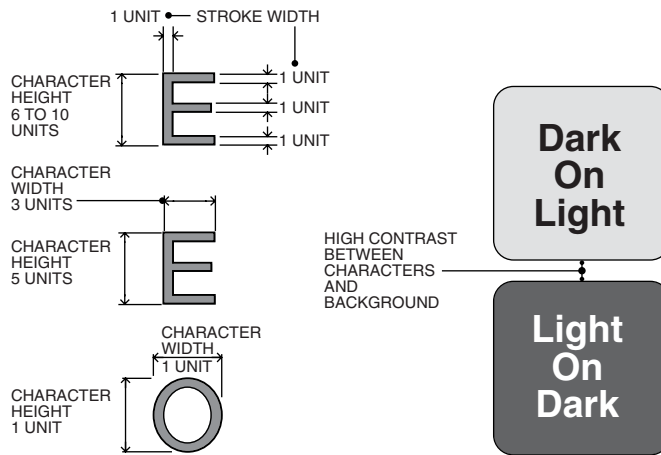

FIGURE 3.8.41. – Sign Characteristics

- g) contain the International Symbol of Accessibility for Persons with Disabilities and any additional wording and symbols necessary to convey full understanding.

There are no copyright restraints on the international symbol of accessibility illustrated in Figure 3.8.42.

Wording used on a sign should be concise. Directional guidance should be restricted to one instruction per sign to avoid confusion. Directional symbols, such as arrows, should be clear and sharp and should not be highly stylized.

Symbols are being used increasingly to assist people in a particular environment. Figure 3.8.43. illustrates a few examples of such symbols with the incorporation of the international symbol of accessibility. On the right is the parking sign described in the Motor Vehicle Act Regulations, Division 23, Schedule 2.

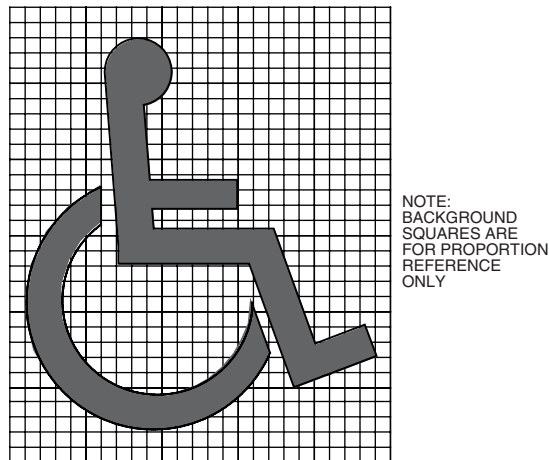

FIGURE 3.8.42. – International Symbol of Accessibility

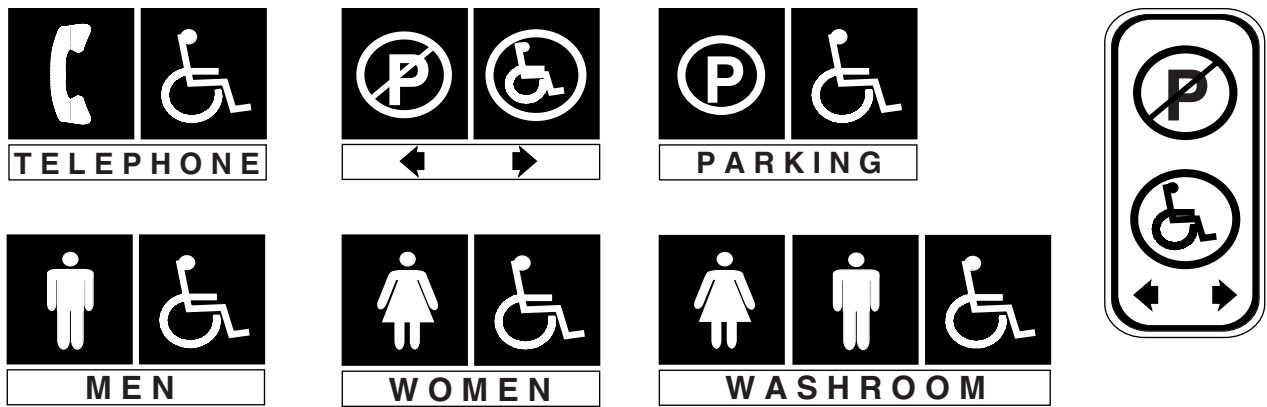

FIGURE 3.8.43. – Examples of Signs

3.8.3.13. Door Numbers

1) To assist persons with a visual impairment, <in occupancies described in Sentence (2),> doors and openings that lead from any public area and through which the public is permitted to pass shall be identified by Arabic numerals or sans-serif letters or both <that> shall be

- a) not less than 25 mm high and raised between 0.7 mm and 3 mm with a high stroke width-to-height ratio for ease of reading by touch, and
- b) located at the side of doors or openings, centered 1 350 mm above the finished floor and within 150 mm of the jamb.

2) The identification of doors and openings <required by Sentence (1)> shall apply to the following *occupancies*:

- a) fine arts *theatres*,
- b) bowling alleys,
- c) court houses,
- d) restaurants,
- e) passenger terminals,
- f) hotels and motels,
- g) offices, including dental and medical offices, and
- h) such other *occupancies*, and parts of *occupancies*, as required by the *authority having jurisdiction*.

Identification of doors and openings greatly assist persons with visual impairments. Discretion should be exercised when applying these requirements in order to avoid excessive and unnecessary application. Identification should be located only at doors and openings to principal rooms and areas within a building, and not to smaller rooms contained within larger rooms or areas. Considering where a member of the public is free to travel in a building will assist in establishing these locations. Signs should have the minimum number of characters to convey their message as reading by touch is slow and embarrassing to some. Figure 3.8.44. gives an example of character proportions and location.

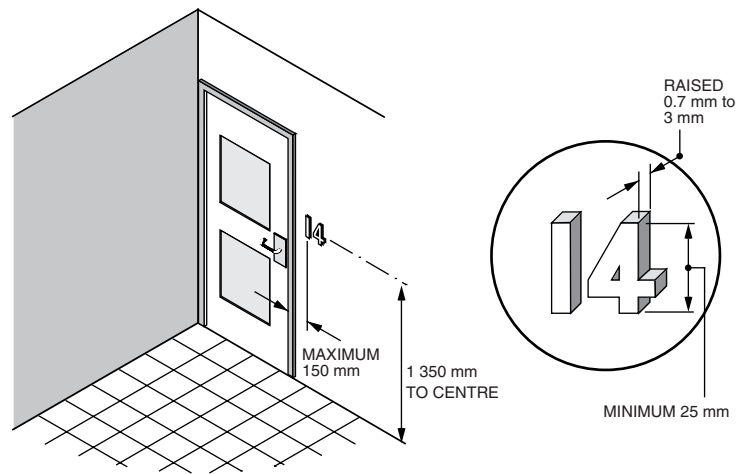

FIGURE 3.8.44. – Room Numbering

3.4.6.19. Floor Numbering

- 1) Arabic numerals indicating the assigned floor number shall
 - a) be mounted permanently on the stair side of the wall at the latch side of doors to *exit* stair shafts,
 - b) be not less than 60 mm high, raised approximately 0.7 mm above the surface,
 - c) be located 1 500 mm from the finished floor and not more than 300 mm from the door, and
 - d) be contrasting in colour with the surface to which they are applied.

The numerical identification of floors should offer maximum contrast to be effective for persons with visual impairments. It is recommended that white on black or black on white be used as this will produce the most contrasting effect for legibility. It is also recommended that signage be designed to avoid glare.

Washrooms

3.7.2.10. Accessible Washrooms

- 1) Where washrooms, baths, or showers are required by Subsection 3.8.2. to be *accessible*, they shall
 - a) be designed to provide manoeuvring space sufficient for a person in a wheelchair to access each type of fixture required to be usable by persons in wheelchairs, and

One of the major problems encountered by persons who use wheelchairs, is entering and using washrooms. Doors that are too narrow with either a second door in close proximity to the first or a privacy screen or wall can make a washroom completely inaccessible (See comment under Subclause 3.3.1.13.(10)(b)(ii), page 31). Where possible, eliminate the doors altogether and only use two doors in succession where there is no alternative. Where privacy screens are used there must be ample room for persons in wheelchairs to manoeuvre around them.

Within the washroom, sufficient space is required to allow persons in wheelchairs to move freely to and from the various accessible fixtures. Figure 3.8.45. illustrates a washroom layout that meets these requirements. A preferred optional layout for a toilet stall for persons in wheelchairs is shown on the female side with an acceptable standard layout shown on the male side.

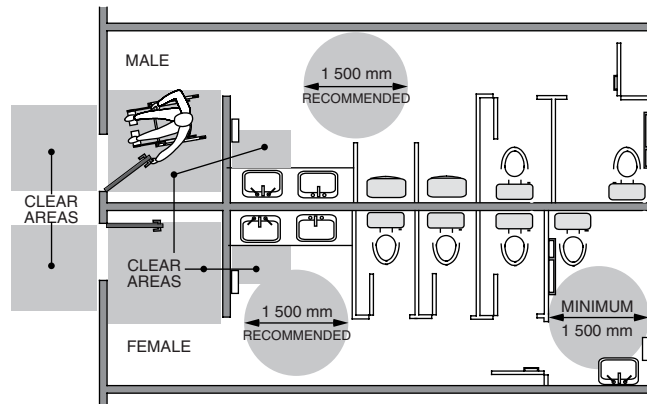

FIGURE 3.8.45. – Washrooms

- b) except as permitted in Sentence (12), conform to Sentences (2) to (11).

Toilet Compartment

2) At least one toilet compartment shall

- a) be not less than 1 500 mm wide by not less than 1 500 mm deep,

Some wheelchair users can transfer from a wheelchair to a toilet from either the front, the side, or obliquely but most prefer a side transfer. A code conforming toilet compartment allows for any of these transfer methods to be employed. Figure 3.8.46. illustrates the side, or lateral, transfer sequence. Some people must back into the stall so the door should be offset from the toilet as shown in Figure 3.8.46. and 3.8.48. Ceiling-hung dividers aid manoeuvrability by providing additional clearance for wheelchair footrests.

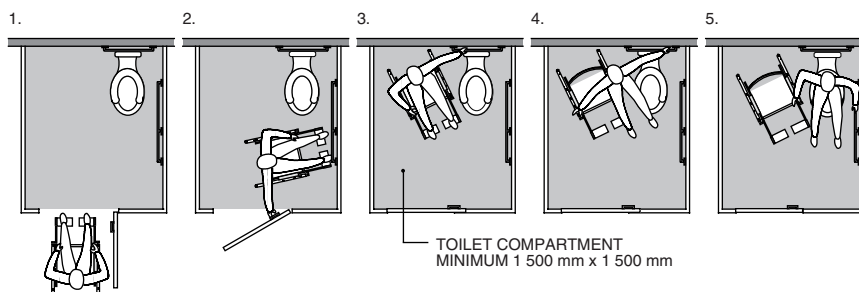

FIGURE 3.8.46. – Wheelchair Transfer Sequence

- b) have a clearance of not less than 1 700 mm between the outside of the stall and the face of an in-swinging washroom door and 1 400 mm between the outside of the stall and any wall mounted fixture,
- c) have a door opening out, with a clear opening width of not less than 800 mm,
- d) have a graspable pull on the inside face of the door at least 140 mm long located with the midpoint between 200 mm and 300 mm from the hinge edge of the door and between 800 mm and 1 000 mm above the finished floor,
- e) be provided with graspable pull on the outside at least 140 mm long near the latch side of the door,
- f) be capable of being latched from the inside with a closed fist, and

The latch to secure the toilet compartment door should be operable without tight grasping or twisting of the wrist unlike the typical rotary device which is almost flush with the door surface.

- g) be equipped with a coat hook mounted not more than 1 200 mm above the floor on a side wall and projecting not more than 50 mm from the wall.

The toilet paper dispenser should be in an accessible location, typically on the wall below the grab bar.

Toilets

3) Water closets in toilet compartments described in Sentence (2) shall

- a) be located with the centre line of the fixture between 420 mm and 480 mm from the side wall carrying the grab bar and at least 1 020 mm from any obstruction on the non grab bar side,

The 1 020 mm clearance on the non grab bar side of the toilet is for the wheelchair to allow for a side transfer to and from the toilet. This clearance is minimal and more should be provided where possible. It is important that no obstructions such as waste receptacles or toilet paper dispensers (which cannot be reached anyway) are located in this space.

- b) have the seat at 430 mm to 480 mm above the floor,

To facilitate transfer from a wheelchair to a toilet and vice versa, the levels should be the same, or the toilet seat should be slightly lower than the wheelchair seat. The optimum height to the top of the toilet seat seems to be 475 mm, which corresponds to the seat height of many wheelchairs.

Removable high-lift seats are not acceptable in public washrooms as they will most likely disappear or be damaged. Permanently installed vandal- and theft-resistant high-lift seats are available for installation on standard height toilet bowls and this combination could be considered as an alternate to the high bowl and regular seat required by this Clause.

- c) have a toilet seat that is not the spring-up type,
- d) have *accessible* hand-operated flushing controls,

The flush control needs to be on the transfer or non grab bar side of the toilet tank to be accessible. A wall mounted flush valve should have its handle facing the non grab bar side and be not more than 1 100 mm above the floor.

- e) where tank-type water closets are provided, have tank lids bolted down, and

Persons with disabilities use the toilet tank for physical support when transferring and also when using the toilet. Having the tank lid bolted down eliminates the possibility of the lid slipping. It is worth noting that persons with disabilities generally prefer tank type toilets to the flush-valve style.

- f) where tank-type water closets are not used, have a toilet seat cover that rests against the grab bar referenced in Clause 3.7.2.10.(4)(b) at an angle of between 95° and 110° to provide back support.p

Some persons with disabilities need back support when using the toilet. The toilet seat cover will provide useful back support if, when raised, it is at approximately 95° to 105° to the seat. Instead of using a toilet seat cover for back support a permanent support can be attached to the wall or the flush valve riser pipe.

Grab Bars

4) Toilet compartments described in Sentence (2) shall

- a) have grab bars that
 - i) <are 30 mm to 40 mm in diameter,
 - ii) are not less than 900 mm long,
 - iii) are mounted with a clearance of 35 mm and 45 mm from the wall, and
 - iv) are mounted horizontally between 840 mm and 920 mm above the finished floor, with the mid-point of the length in line with the front edge of the water closet, and
 - v) may be angled upward at the mid-point of the length not more than 60° from the horizontal forward of the water closet, and

The grab bar that angles upward from its mid-point is the preferable design as it is more useful to more people.

It is highly recommended that grab bars have a non-slip finish.

- b) where tank-type water closets are not used, have a second bar not less than 600 mm long, mounted on the wall behind, and centred over, the water closet with the centre line between 815 mm and 865 mm above the finished floor.>

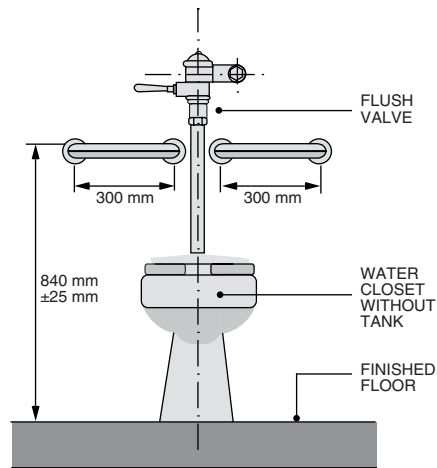

FIGURE 3.8.47. – Grab Bars (Alternative)

In situations where a high flush valve interferes with the location of the grab bar, an acceptable alternative is a 300 mm grab bar on each side of the flush valve as shown in Figure 3.8.47. Better yet is an adequately braced grab bar which projects far enough from the wall to clear the flush valve pipe but not so far as to interfere with the toilet seat cover performing as a back rest.

Wash basins

- 5) At least one wash basin shall
- a) be located
 - i) with its centre line not less than 460 mm from a side wall
 - ii) with its rim not more than 865 mm above the finished floor,
 - iii) with a vertical clearance of not less than 735 mm under the front edge,
 - iv) with a clear area centered under the wash basin not less than 760 mm wide and reducing to not less than 685 mm high at a point 250 mm back from the front face of the apron, and
 - v) with a further clear space 250 mm above the floor to a point 500 mm back from the front face of the apron,

Figure 3.8.49. illustrates the need for clearance under a wash basin. Although the clear space requirements shown are minimum, minor features, such as the wash basin's front overflow drain, may project into this space provided it can be shown that such projections will not interfere with the ability of persons in wheelchairs to reach the faucet lever(s) and accessories located at the wash basin. The use of an offset trap (as shown) also ensures that the wheelchair footrest space is clear of obstructions.

It should be noted that some wall hung lavatories cannot be installed in a conforming manner because they are not deep enough, front to back, to allow for the minimum 500 mm clearance to the wall below the sink. They may also be too high if mounted to provide sufficient knee clearance under the apron.

A 750 mm deep vanity counter with the sink installed close to the front is a good design for an accessible wash basin. Vanity counters must have deep aprons cut away to provide the minimum 735 mm vertical clearance and such cut-outs should be at least 800 mm wide. An accessible shelf is recommended when a basin is not in a vanity counter.

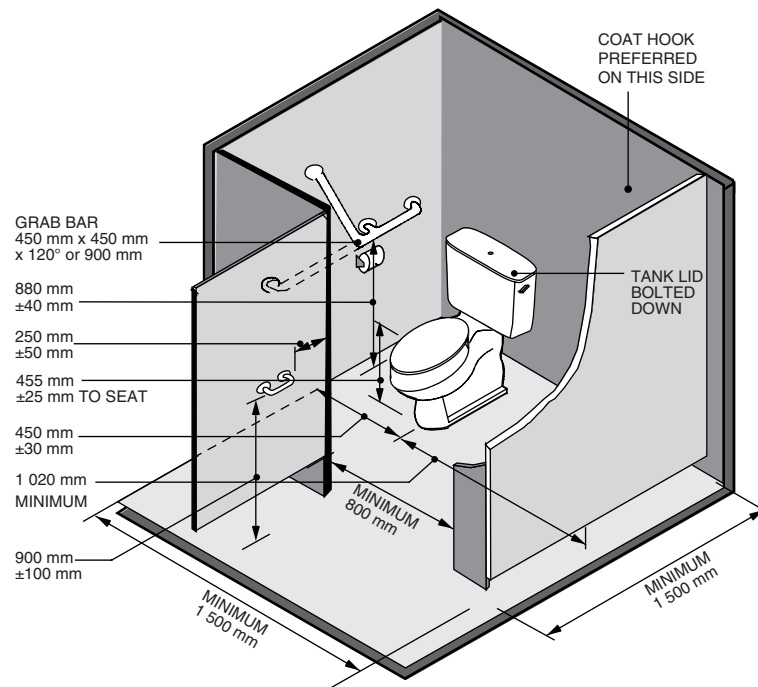

FIGURE 3.8.48. – Toilet Compartment

- b) have a clear floor space centred in front of the wash basin not less than 800 mm wide and 1 100 mm deep exclusive of space under the wash basin,
- c) have pipes insulated where they may constitute a burn hazard to persons in wheelchairs,
- d) have faucets conforming to Sentence 3.7.2.3.(4), [p. 60]
- e) have a soap dispenser located close to the wash basin, not more than 1 200 mm above the finished floor and *accessible* to persons in wheelchairs, and
- f) have a towel dispenser or other hand-drying equipment located close to the wash basin, not more than 1 200 mm above the finished floor in an area *accessible* to persons in wheelchairs.

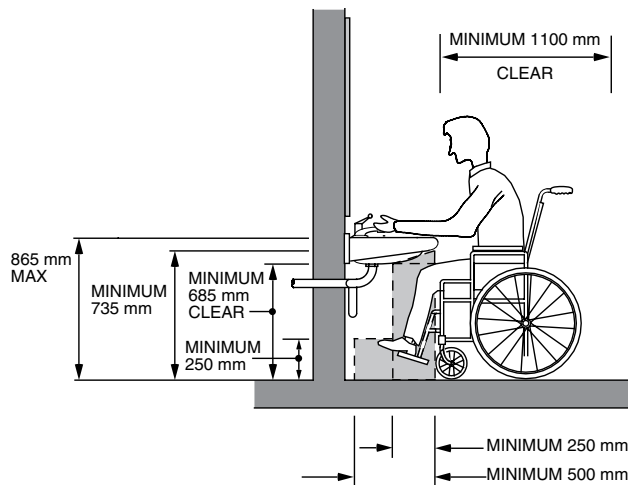

FIGURE 3.8.49. – Clearance Under Wash Basin

3.7.2.3. Lavatories

- 4)** Lavatories required by Sentence (1) shall be equipped with faucets that
- a) operate automatically, or
 - b) have lever-type handles that do not close under spring action.

Faucets must be of such a design as to be operable without tight grasping, pinching or twisting of the wrist. Figure 3.8.50. shows examples of handles that are generally usable by people who have little or no use of their hands. The extra length of the handles serve as a fulcrum to allow use with a minimum of pressure. Faucets must be within reach of the user and to this end the wash basin/faucet assembly should be as close to the front of a vanity as possible while still maintaining the required clearances. Installing a single lever faucet at the side of the basin provides excellent accessibility for all users.

It is recommended that the water temperature at such fixtures be controlled as persons with disabilities who have little or no sensation in their hands can burn their hands quite easily.



FIGURE 3.8.50. – Faucets

Urinals

3.7.2.10.

6) Where urinals are provided in place of required water closets as described in Sentence 3.7.2.2.(5) [B.C. Building Code], at least one shall

- a) be either wall-mounted with the opening of the basin between 490 mm and 510 mm above the finished floor, or floor-mounted with the rim level with the finished floor, with no step being permitted in front of either type of urinal,
- b) have a clear width of approach of 800 mm centred on the urinal, and
- c) be provided on each side with vertical grab bars not less than 300 mm long mounted not more than 380 mm from the centre line of the urinal with their mid-point 1 000 mm above the floor.

This requirement assists small children as well as some persons with disabilities who can use a urinal if it is mounted at this lower height and grab bars are provided.

Mirror

7) Where mirrors are provided, at least one shall be mounted with its bottom edge not more than 1 000 mm above the finished floor, or shall be tilted to be usable by persons in wheelchairs.

Mirrors installed with their bottom edge at the top of the vanity counter or wall hung lavatory are preferred.

Accessories

8) At least one of each washroom accessory shall be of a type, and be installed, so as to be usable by persons in wheelchairs with no user function more than 1 100 mm from the finished floor

3.7.2.3. Hazardous Projections

3) Any shelf or projection above a lavatory shall be located so that it will not be a hazard.

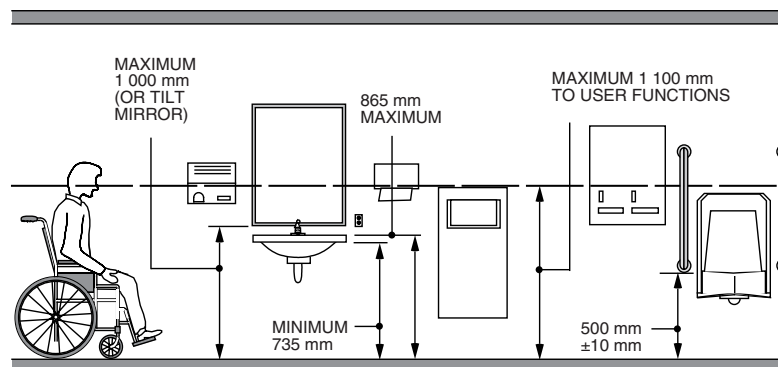

FIGURE 3.8.51. – Washroom Accessories

When locating accessories consideration should be given to keeping them in close proximity to the accessible wash basin. Soap dispensers and towel dispensers or warm air dryers are required to be close to the sink (3.7.2.10.(5)(e) & (f) [p. 59]). Imagine someone in a wheelchair trying to wash their hands when the soap is at the opposite end of the counter from the accessible sink and the towel dispenser is on the other side of the room. It is difficult to wheel from place to place with wet hands. Soap and towel dispensers are best located on a wall beside the sink.

Convenient location of fixtures and accessories is a benefit to all washroom users not just persons with disabilities. The accessories must also be usable by people with limited hand functions. Figure 3.8.51. illustrates the dimensional requirements of Sentences (5), (6), (7), and (8).

Universal Toilet Room

3.7.2.10.

9) A universal toilet room shall have

- a) a floor space of not less than 3.7 m² with no dimension less than 1 700 mm when the door swings out and 4.0 m² with no dimension less than 1 800 mm when the door swings in,

Wall-mounted fixtures may project into the required floor space, provided that such projections do not restrict the manoeuvring space required for persons in wheelchairs.

Recessed fixtures and wall-mounted fixtures with deep recesses on the underside greatly improve the ability of a person to manoeuvre a wheelchair.

- b) fixtures located to provide maximum manoeuvrability for persons in wheelchairs,
- c) a water closet that conforms to Sentence (3), with grab bars conforming to Clauses (a) and 3.7.2.10.(4)(b),
- d) a wash basin conforming to Sentence (5),
- e) at least one mirror conforming to Sentence (7),
- f) washroom accessories conforming to Sentence (8),
- g) a lock on the entrance door that is operable with one hand and can be unlocked from the outside in case of emergency, and
- h) on an outward swinging door a pull conforming to Clause (2)(d).

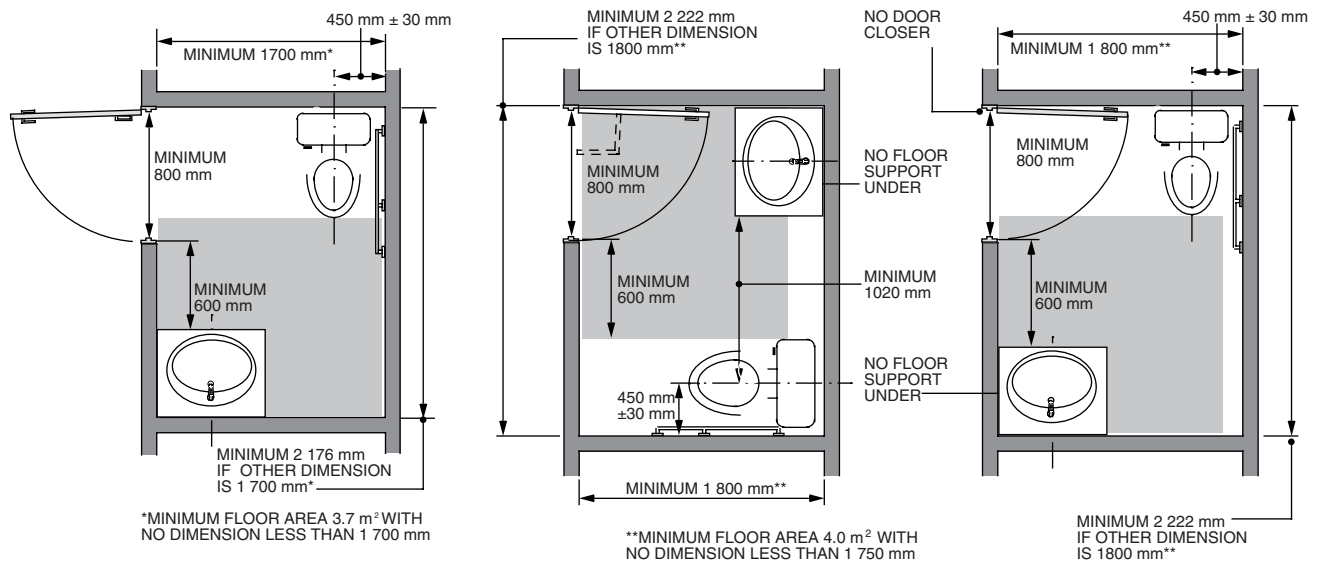

FIGURE 3.8.52. – Suggested Toilet Room Layouts

Figure 3.8.52. gives examples of accessible toilet rooms. The layouts shown can be altered only minimally; for example, the location of the entry door. A great deal of care should be taken with layouts other than those shown and if other layouts are anticipated the floor area may have to be increased. The first and second designs are preferred because emergency access to the toilet room is not blocked by the person's wheelchair.

Innovative designs using unusual room shapes and/or recessed wash basins may be possible and can be suggested to the building official as alternate solutions under Subsection 2.2.7. in Division C of the B.C. Building Code. Such designs should be mocked up and tried before proposing an alternate solution.

Note that in one of the layouts the door has no closer. The shaded areas indicate minimum 1 500 mm x 1 500 mm clear floor areas.

See commentary starting on page 55 regarding flush valves, grab bars, toilet clearances, wash basins and accessories.

Baths

10) Baths shall

- have a clear floor area in front of the bath not less than 1 500 mm long by 800 mm out from the bath, with fixtures being permitted to project into such clear area provided that *access* to the bath controls from a wheelchair is not restricted,
- have faucets conforming to the requirements of Sentence 3.7.2.3.(4),
- have shower selector controls that meet the requirements for faucets described in Clause (b),
- have a water supply that is controlled by a pressure-equalizing valve or by an automatic thermostatically-controlled valve,
- to permit lateral transfer from a wheelchair, have a removable seat <that> is
 - designed to remain stable during use,
 - wide enough to give stability to the user,
 - capable of carrying a load of not less than 1.33 kN, and

- iv) manufactured so as to be impervious to water and of such a design as to be easily cleaned,
- f) have a telephone-type shower located at the same end of the bath as the controls, where a shower is provided,
- g) have an integral slip-resistant bottom,
- h) not have shower doors,

The tracks for sliding shower doors interfere with a person transferring from a wheelchair to the bath. Hinged shower doors can restrict access to the bath. This Clause is not intended to prohibit shower curtains.

As shown in Figure 3.8.53. the shower head and its control is best located on the side wall where it is easily reached while seated. The controls to fill the tub are best located on the end wall offset towards the outside of the tub where they can be easily reached from a wheelchair before entering the tub.

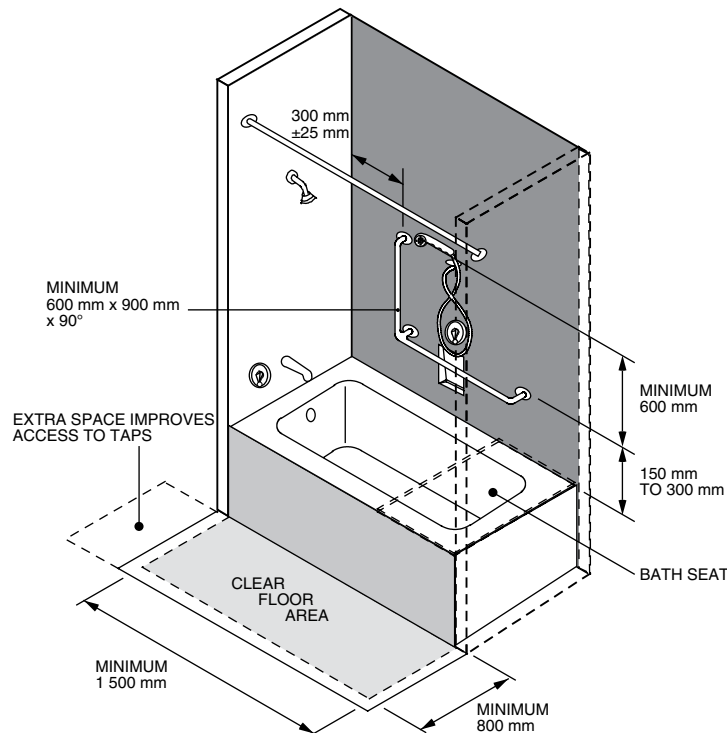

FIGURE 3.8.53. – Bath

- i) have fully-recessed soap holders within reach from the seated position, and
- j) have <L-shaped> grab bars that
 - i) <have a horizontal section of not less than 600 mm, a vertical section of not less than 900 mm and a 90° angle,
 - ii) are mounted with the centre line of the vertical section 275 mm and 325 mm away from the control end of the bath and the centre line of the horizontal section 150 mm to 300 mm above the rim of the bath, and
 - iii) conform to Subclauses (4)(a)(i) to (a)(v).

Figure 3.8.53. illustrates an accessible bath.

Shower Compartments

11) Shower compartments shall

- a) be not less than 1 500 mm wide by 900 mm deep with <an entrance not less than 1 500 mm wide>,
- b) have a clear floor area in front of the entrance to the shower not less than the width of the shower by 900 mm deep, with fixtures being permitted to project into the clear area provided that *access* to and from the shower compartment is not restricted,
- c) have faucets that
 - i) conform to the requirements of Clause (5)(d), and
 - ii) are located so as to be usable from the seated position,
- d) to permit lateral transfer from a wheelchair, be provided with a portable or wall-mounted folding seat <that> is
 - i) located between 430 mm and 480 mm above the finished shower floor on a side wall,
 - ii) 40 mm to 60 mm less than shower compartment depth by between 430 mm and 530 mm wide,
 - iii) capable of carrying a minimum load of 1.33 kN, and
 - iv) manufactured so as to be impervious to water and of such a design as to be easily cleaned,
- e) have a telephone-type shower, located so as to be within reach from the seated position,
- f) have a water supply that is controlled by a pressure-equalizing valve or by an automatic thermostatically controlled valve,
- g) not have shower doors,

See comment under Clause 3.7.2.10.(10)(h) on page 64.

- h) have thresholds that do not exceed 13 mm in height and are bevelled,
- i) have fully-recessed soap holders within reach from the seated position, and
- j) have <L-shaped> grab bars that
 - i) <have a horizontal section of not less than 750 mm, a second horizontal section of not less than 900 mm and a 90° angle,
 - ii) are mounted with the center line of the grab bar between 700 mm and 800 mm above the shower floor, with the 900 mm section on the side wall opposite the entrance, and
 - iii) conform to Subclauses (4)(a)(i) to (a)(v).>

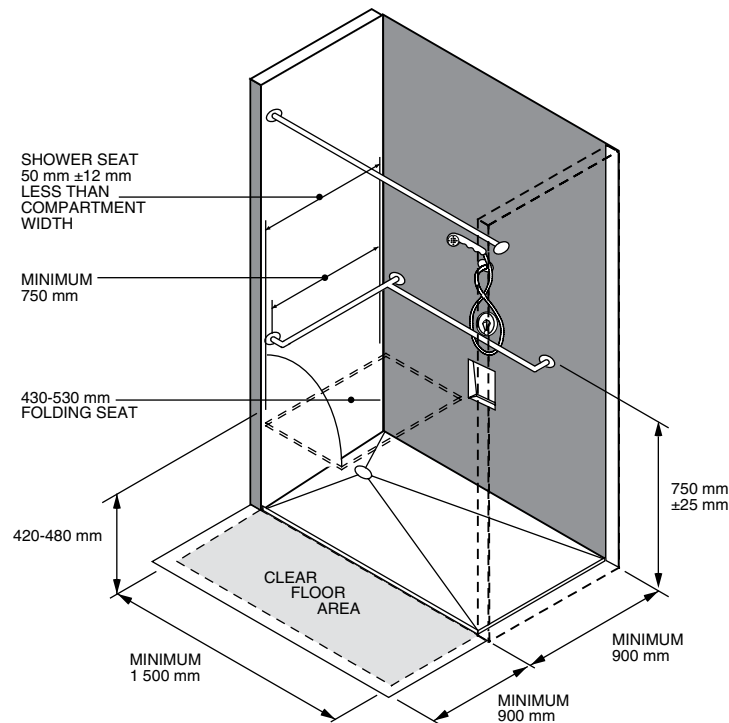

FIGURE 3.8.54. – Shower Compartment

An accessible shower can be incorporated into gang shower areas provided the requirements of Sentence 3.7.2.10.(11) are met. For example, a partial height wall or partition may be all that is necessary to accommodate the seat and grab bars.

Most shower doors impede access into the shower stall due to the size of the opening they provide and/or because of the floor mounted track. Shower curtains are acceptable and doors which would not impede access any more than a curtain should also be acceptable.

The slope of the floor for drainage purposes should be kept to a minimum and the drain is best located under the seat.

Figure 3.8.54. illustrates an accessible shower.

Exceptions

12) In *occupancies* or parts of *occupancies* used predominantly by children, and in patient areas in Group B, Division 2 *occupancies*, it is permissible to locate fixtures and grab bars differently than described in Sentences (2) to (11) to accommodate the special needs of children, patients and care providers.

3.8.3.14. Sleeping Units

1) Where *accessible* sleeping units are required by Subsection 3.8.2. [p. 3 - 17], they shall have

- sufficient space to provide a turning area of not less than 1 500 mm diameter on one side of a bed,
- sufficient space to provide a clearance of not less than 900 mm to allow for functional use of units by persons in wheelchairs,

- c) an *accessible* balcony where balconies are provided,

An accessible balcony would typically be at the same elevation as the floor of the room and have an 800 mm clear width door with a maximum 13 mm threshold. A flush door sill could lead to serious water ingress problems so this door threshold detail must be very carefully designed and constructed if building envelope failure is to be avoided.

- d) at least one closet that provides
- i) a clear opening not less than 900 mm wide,
 - ii) clothes hanger rods capable of being lowered to a height of 1 200 mm, and
 - iii) at least one shelf capable of being lowered to a height of 1 200 mm,
- e) *accessible* light switches, thermostats and other controls that are specifically provided for use by the occupant <and are> located between 900 mm and 1 200 mm above the finished floor,
- f) *accessible* electrical receptacles located between 455 mm and 1 200 mm above the finished floor,
- g) an *accessible* razor outlet where a razor outlet is provided, and
- h) a bathroom, where provided as part of a sleeping unit,
- i) conforming to Sentence 3.7.2.10.(3) [p. 56], except that the water closet seat shall be between 355 mm and 405 mm above the finished floor and shall have available a 115 mm high lift seat having openings on each side and the front for personal hygiene,

Note the specific requirement for a standard height toilet and an available high-lift seat. It is intended that the high-lift seat be stored in the suite or available from the management on request.

- ii) conforming to Clause 3.7.2.10.(4)(a) [p. 57], except that the grab bar need only be not less than 600 mm long with the centre line located 715 mm to 840 mm above the finished floor <and> the bar projecting 50 mm beyond the front edge of the water closet,

A 600 mm long grab bar is acceptable under Subclause (h)(ii). The reason for permitting a shorter grab bar is that in many hotel or motel suite bathrooms the only available location for mounting this grab bar is the front apron of the vanity. Also, the greater tolerance permitted in the mounting height corresponds to the vanity height. Don't forget to provide the required clearance under the wash basin.

- iii) conforming to Clause 3.7.2.10.(4)(b) [p. 57],
- iv) conforming to Sentences 3.7.2.10.(5), (7), (8) and (10) [p. 58 - 63] only to the extent of providing the same type of facilities provided in sleeping units for persons without disabilities, and
- v) having a clear floor space not less than 1 500 mm by 1 500 mm, which may include the water closet.

Figure 3.8.55. illustrates two floor plans of a hotel or motel suite with almost identical floor areas. With minor modifications to the interior partition layout, Suite A is fully accessible. In Suite B, exiting from the rooms is extremely difficult and the bathroom is virtually inaccessible due to the door swinging in.

When sleeping units are provided for persons with disabilities it is recommended that the following be considered:

1. Locate telephones so that they are accessible from both a wheelchair and a bed.
2. Locate controls for T.V., lights and other features so as to be within reach of a person in bed.
3. If no patio doors are provided, at least one window should be located with a sill height of approximately 610 mm.
4. Having the top of a mattress at about the same height as a wheelchair seat, i.e., 450 mm to 500 mm, greatly aids a person in transferring from one to the other.
5. When several accessible suites are provided in a building they should be distributed among the types and price range of suites that are generally available including choice of beds and smoking and non-smoking rooms.
6. Sliding doors for closets and cabinets are preferred but bi-fold doors are also acceptable.
7. Door closers should offer minimum resistance.
8. Use low pile carpeting on firm backing.
9. Windows and coverings should be easy to use from a wheelchair and by persons with limited use of their hands.

See comments to Sentences 3.3.1.13.(10) & (11). [p. 31]

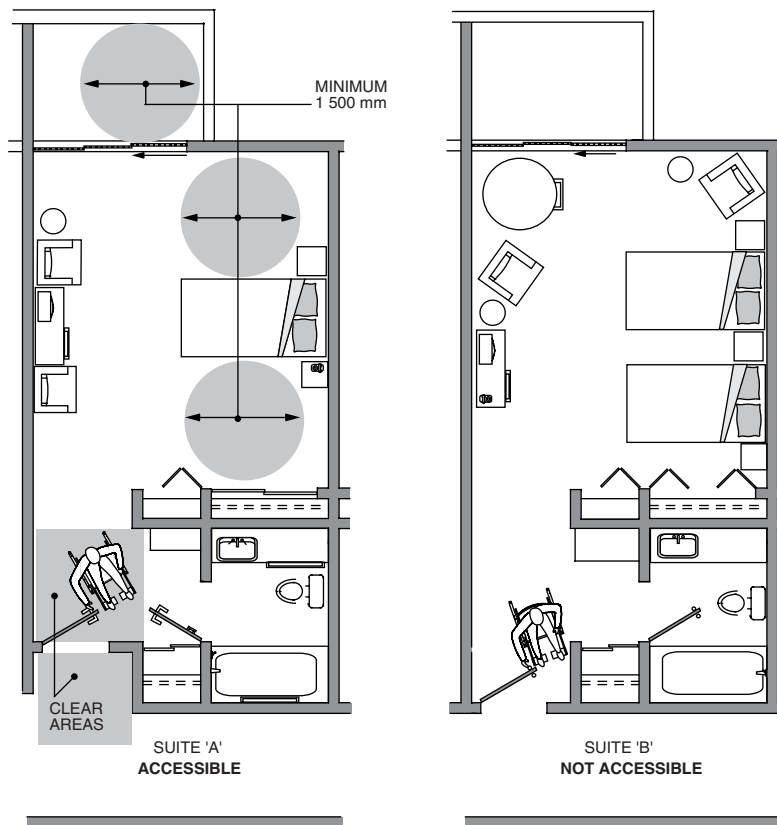

FIGURE 3.8.55. – Suite

3.7.2.9. Bathtubs

- 1) Where a bathtub is installed in a hotel or a motel, it shall
 - a) notwithstanding the presence of a water closet or a lavatory, have a clear floor space at least 750 mm wide along its length,
 - b) have faucets that conform to Clause 3.7.2.3.(4)(b),
 - c) have grab bars that
 - i) conform to Sentence 3.7.2.8.(1),
 - ii) are 1 200 mm long located vertically at the end of the bathtub that is adjacent to the clear floor space, with the lower end between 180 mm and 280 mm above the bathtub rim, and
 - iii) are 1 200 mm long located horizontally along the length of the bathtub at 180 mm to 280 mm above the bathtub rim, and
 - d) be open along its length with no tracks mounted on the bathtub rim.

This is a new provision that requires “accessible” bathtubs in all hotel or motel rooms that are provided with bathtubs. This provision is similar to Sentence 3.7.2.10.(10) but is not specifically intended for the disabled. The provision provides safety and access for a wide range of users.

3.8.3.15. Viewing Positions

- 1) Each viewing position required by Subsection 3.8.2. shall be
 - a) either
 - i) a level area with removable seating to allow the space to be used by persons in wheelchairs, or
 - ii) a clear and level area not less than 900 mm wide and either 1 525 mm long to permit side entry of the wheelchair or 1 220 mm long where the wheelchair enters from the front or rear of the space and shall provide a clear view of the event taking place,

Many people in wheelchairs travel with an ambulant companion and they should be able to sit together. To provide for this the 900 mm width can be increased to 1 400 mm to accommodate a removable seat supplied by the theatre. Wheelchair viewing positions can also be located adjacent to regular seats provided the viewing position is level. Persons in wheelchairs usually sit higher than people in adjacent seats and care should be taken that viewing positions for persons in wheelchairs are arranged so as not to obstruct the view of people who may be seated behind.

- b) arranged so that at least two positions are side by side, and

Viewing positions should be neither bunched together nor completely segregated but should be distributed throughout the seating to allow a reasonable choice of location and ticket price. “Side by side” is intended to allow viewing positions across an aisle from each other as well as immediately adjacent.

- c) located so as not to interfere with egress from any row of seating or infringe on any aisle requirements.

Figure 3.8.56. shows suggested locations for seating in a theatre. (See comment under Sentence 3.8.3.15.(2), below.)

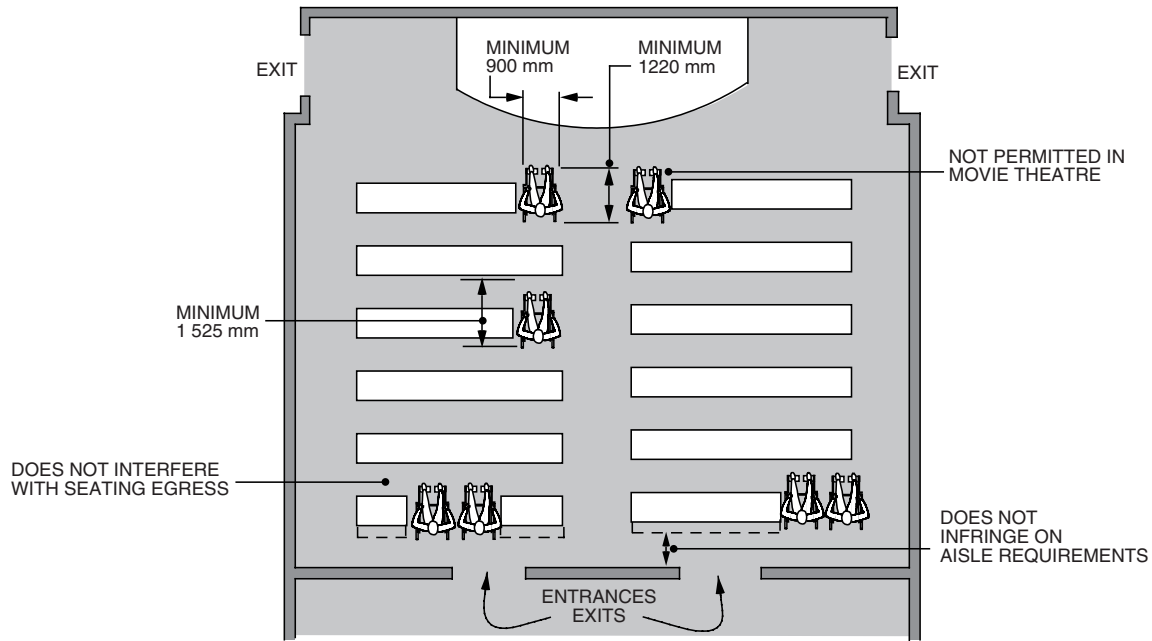

FIGURE 3.8.56. – Theatre Viewing Positions

- 2)** In motion picture theatres, viewing positions shall not be located in the front third portion of the seating area.>

It is desirable that the viewing positions in Group A, Division 1 occupancies be located in close proximity to an exit and that both the building management and the fire department be aware of such locations, in the event of an emergency.

Figure 3.8.57. illustrates how viewing positions may be provided in a stadium or arena.

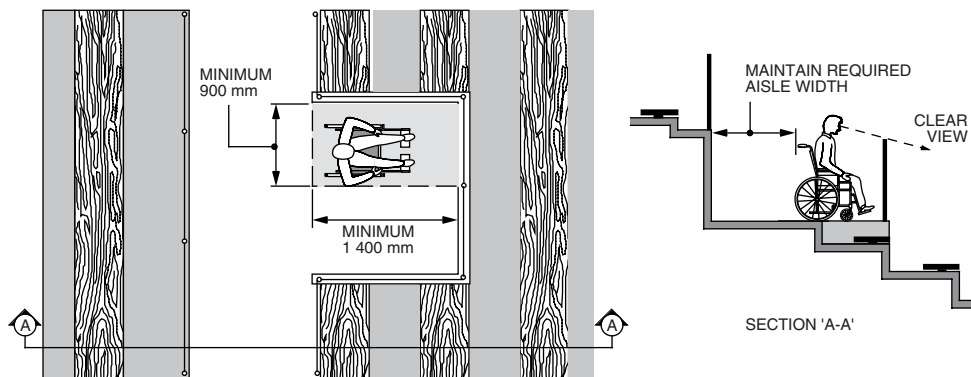

FIGURE 3.8.57. – Stadium or Arena Viewing Positions

3.8.3.16. Public Telephones

- 1) In each location where more than one public telephone is installed, at least one <Public Telephone> shall
- a) be provided with unobstructed *access*, not less than 800 mm wide and 800 mm deep, <to within 300 mm of the front of the telephone,>
 - b) have a vertical clearance of not less than 715 mm under a directory shelf,
 - c) have the centre of the coin slot not more than 1 200 mm above the finished floor,
 - d) have an adjacent shelf at least 250 mm wide by 350 mm deep with a clearance above the shelf of at least 250 mm,

Many persons with hearing impairments use a telecommunication device for the deaf (TDD) connected to a standard telephone. A shelf is needed to hold this device.

- e) have a handset incorporating a hearing aid coupler coil, and
- f) be identified as being usable by persons in wheelchairs and persons with a hearing disability.

Figure 3.8.58. illustrates one example of an accessible public telephone installation. Locating the coin slot at 900 mm provides much improved accessibility. Installing the phone so it can be approached side on with a counter beside it, rather than below as shown, is also a good way to provide an accessible telephone. Note the sign indicating the phone is equipped with an amplifier. (See commentary to Article 3.3.1.9. [p. 28] regarding protruding objects.)

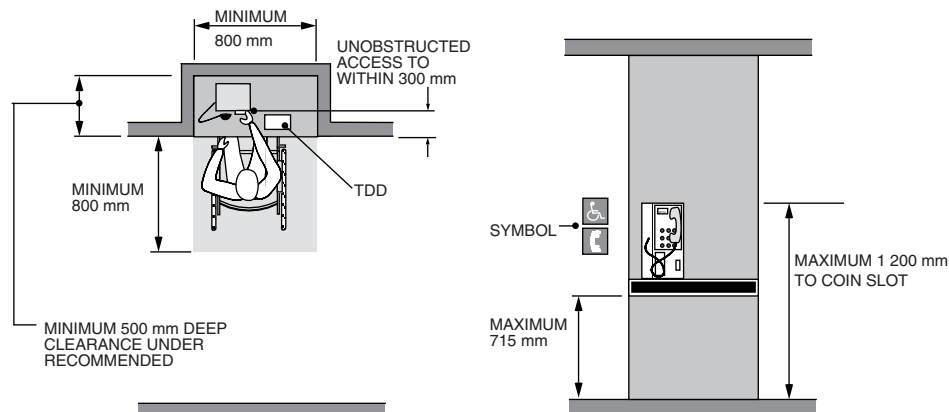

FIGURE 3.8.58. – Public Telephone

Drinking Fountains

3.8.3.17.

- 1) In each location where drinking fountains or fountains are installed, <at least> one fountain shall
- a) have a spout opening not less than 750 mm nor more than 915 mm above the finished floor,

It is recommended that the spout be set close to the front of the fountain with the preferred direction of flow of water being parallel to the front of the fountain.

- b) have lever or push-bar controls operable by a force of not more than 22 N, located either on the front or on both sides, <and
- c) where located in an alcove, conform to Sentence (2).>

2) <A drinking fountain described by Clause (1)(c) shall

- a) be located in an alcove not less than 800 mm wide, and
- b) be of the surface-mounted type.>

Figure 3.8.59. illustrates a surface-mounted drinking fountain installed in an alcove.

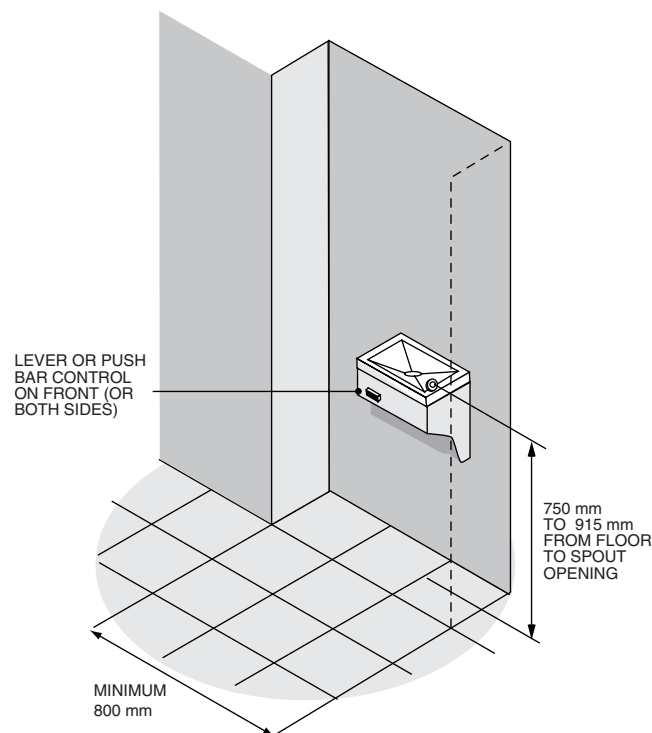

FIGURE 3.8.59. – Drinking Fountain

Counters

3.8.3.18.

1) <Where counters serving the public and intended as a work surface for extended business transactions are provided, at least one *accessible* counter shall be provided that

- a) has its work surface not more than 865 mm above the floor and
- b) is not less than 760 mm long centred over the knee space required by Sentence (2).

(See Appendix A)(See also A-3.8.2.1. in Appendix A.) >

2) Knee space beneath an *accessible* counter intended to be used as a work surface shall be not less than

- a) 760 mm wide,
- b) 685 mm high, and
- c) 485 mm deep.

Figure 3.8.60. illustrates an accessible counter. (See Article 3.8.2.33. [p. 15])

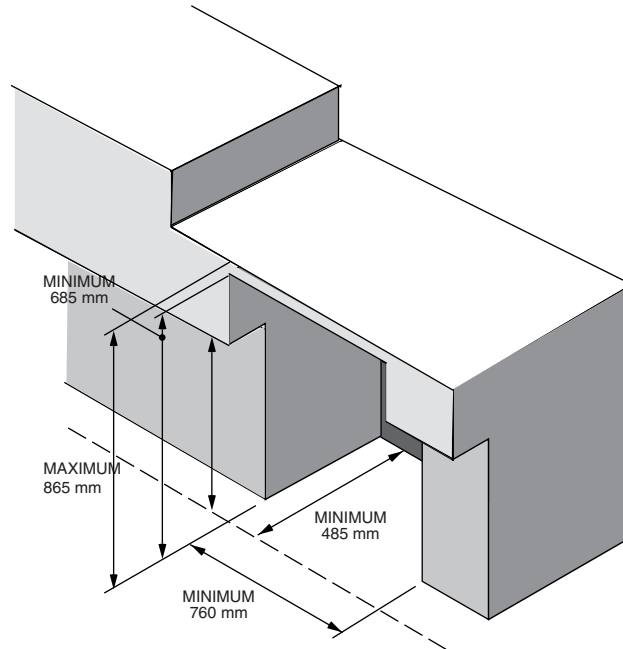

FIGURE 3.8.60. – Counter

3.8.3.19. Egress from Floor Areas

1) Every *floor area* that is not sprinklered throughout and that is required to be *accessible* shall

- a) be served by an elevator
 - i) conforming to Sentences 3.2.6.5.(4) to (6) [B.C. Building Code],
 - ii) protected against fire in conformance with Clauses 3.2.6.5.(3)(b) or (c) [B.C. Building Code], and
 - iii) in a *building* over 3 *storeys* in *building height*, protected against smoke movement so that the hoistway will not contain more than 1% by volume of contaminated air from a fire floor during a period of 2 h after the start of a fire, assuming an outdoor temperature equal to the January design temperature on a 2.5% basis determined in conformance with Article 1.1.3.1.,

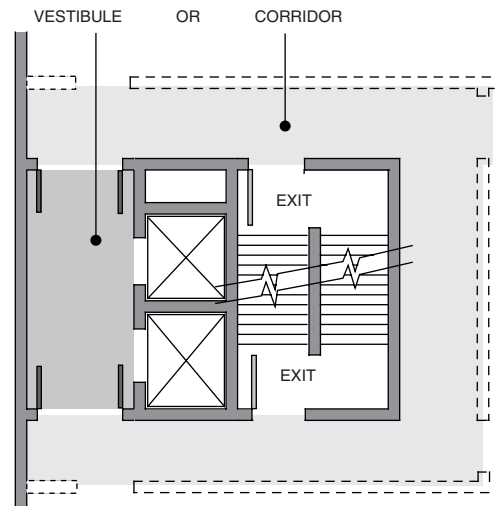

FIGURE 3.8.61. – Protected Elevator

- b) be divided into at least 2 zones by *fire separations* conforming to Sentences (2), (3) and (4) so that
 - i) *persons with disabilities* can be accommodated in each zone, and
 - ii) the travel distance from any point in one zone to a doorway leading to another zone shall be not more than the travel distance permitted by Sentence 3.4.2.5.(1) [B.C. Building Code] for the *occupancy* classification of the zone,
- c) in the case of *residential occupancies*, be provided with balconies conforming to Sentence (5), except on the *storey* containing the *accessible* entrance,
- d) have an *accessible* exterior *exit* at ground level, or
- e) have a ramp conforming to Article 3.8.3.3. leading to ground level.

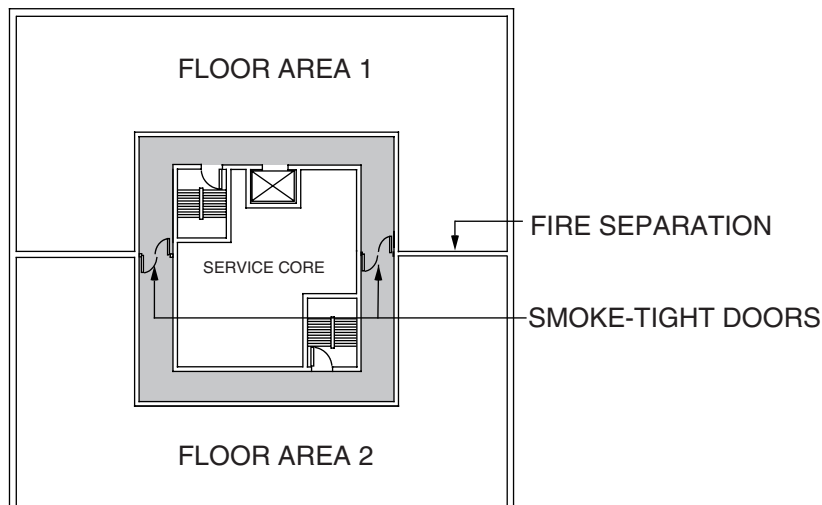

FIGURE 3.8.62. – Divided Floor Area

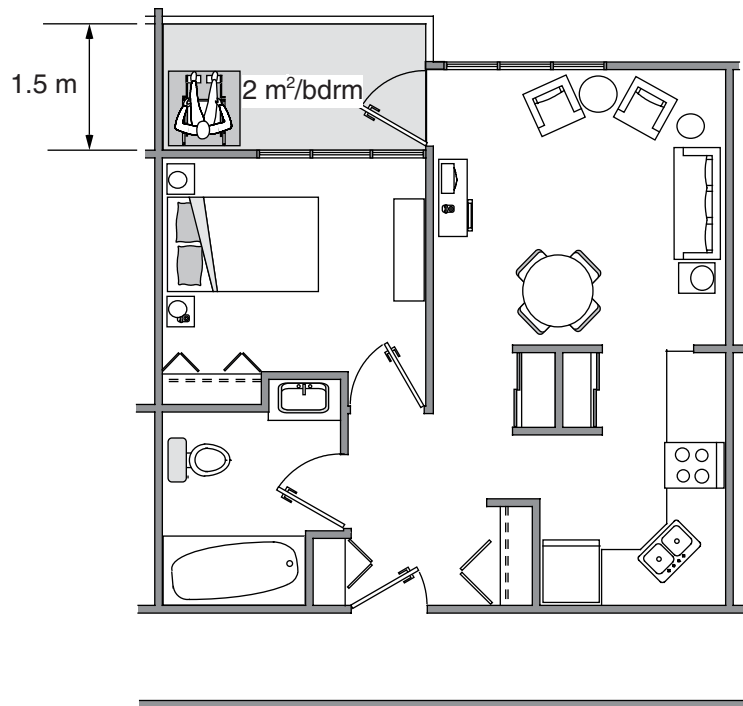

FIGURE 3.8.63. – Residential Balcony

2) Except as permitted by Sentence (3), the *fire separations* referred to in Clause (1)(b) shall have a *fire-resistance rating* not less than 1 h.

3) The *fire-resistance rating* of the *fire separations* referred to in Clause (1)(b) is permitted to be less than 1 h but not less than 45 min provided the *fire-resistance rating* required by Subsection 3.2.2. [B.C. Building Code] is permitted to be less than 1 h for

- a) the floor assembly above the *floor area*, or
- b) the floor assembly below the *floor area*, if there is no floor assembly above.

4) A *closure* in a *fire separation* referred to in Clause (1)(b) shall be weatherstripped or otherwise designed and installed to retard the passage of smoke.

5) A balcony required by Clause (1)(c) shall

- a) have direct *access* from the *suite* or *floor area*,
- b) be not less than 1.5 m deep from the outside face of the exterior wall to the inside edge of the balcony, and
- c) provide not less than 2 m² of balcony space for each *accessible* sleeping room.

These egress requirements are intended to provide temporary refuge for persons with disabilities. It is acknowledged, however, that the measures cannot provide absolute safety for all occupants in the fire area. It may, therefore, be necessary to develop special arrangements in the fire safety plan to evacuate persons with disabilities from these areas. Details for a suitable plan are contained in the B.C. Fire Code.

The protected elevator referred to in Clause 3.8.3.19.(1)(a) is intended to be used by fire fighters as a means for evacuating persons with disabilities. It is not intended that this elevator be used by persons with disabilities as a means of egress without the assistance of fire fighters.

If an estimate is to be made of the number of persons with disabilities in a floor area who can be accommodated in each zone in Clause 3.8.3.19.(1)(b), this estimate may be based on Table 3.8.2.5. in the B.C. Building Code, which is used to determine the minimum number of spaces to be provided for wheelchair occupants in fixed seating areas. If more precise information is available, it should be used for sizing the zones.

3.8.3.20. Assistive Listening Devices

1) Where assistive listening systems are required they shall be provided throughout the entire seating area except that with an induction loop system only half the seating area need be encompassed.

Wireless sound transmission systems such as FM, infrared or magnetic induction loop, improve sound reception for the hard of hearing by providing amplification which can be adjusted by each user while blocking out unwanted background noise. These systems transmit a signal that is picked up by special receivers available for use by persons with a hearing impairment, whether or not they use a hearing aid. Neither system interferes with the listening enjoyment of others.

The induction loop system requires users to sit in the area surrounded by the loop whereas FM and infrared systems can be designed to broadcast signals which cover the entire room. Although portable systems are permitted they are best suited to small audiences. Good acoustics are required for any of these systems to function adequately. More information is available from the Canadian Hard of Hearing Association, B.C. Chapter. (www.chha.ca)

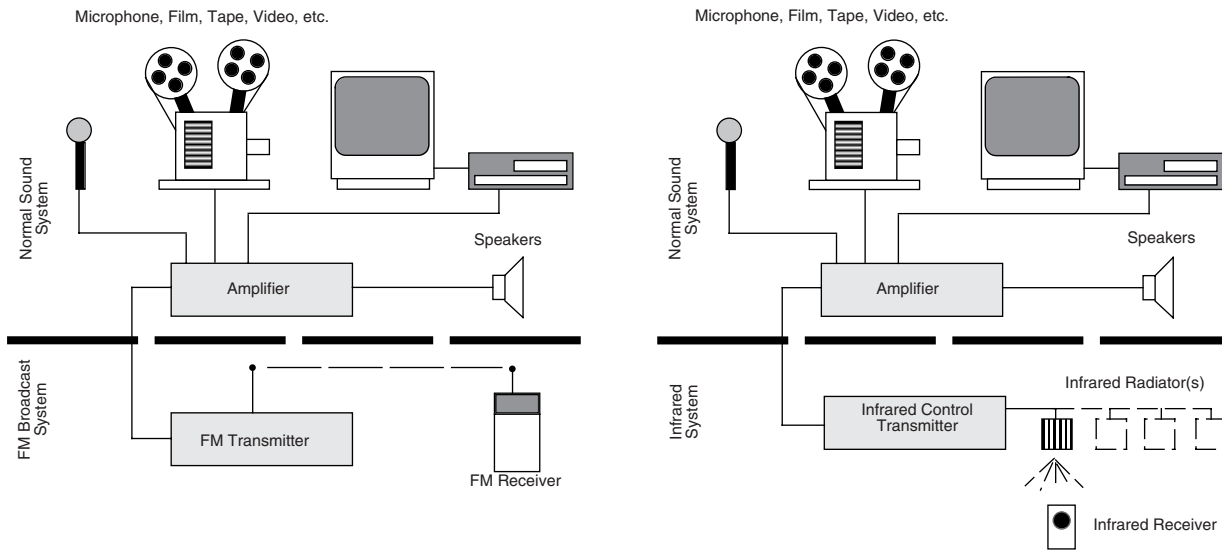

FIGURE 3.8.64. – Assistive Listening Systems

3.8.3.21. Controls

1) Except as required by Sentence 3.5.2.1.(3) for elevators, controls for the operation of building services or safety devices, including electrical switches, thermostats and intercom switches, intended to be operated by the occupant and located in or adjacent to an accessible path of travel shall be

- a) <accessible to a person in a wheelchair,

- b) operable with one hand, and
- c) mounted between 400 mm and 1 200 mm above the floor.>

3.8.4. Alterations and Additions to Existing Buildings

3.8.4.1. Application

1) Except as provided in <Sentence (2),> *access* as described in Articles 3.8.4.2. to 3.8.4.8. shall be provided

- a) <to additions to existing *buildings* where such additions have internal pedestrian connections with the existing *buildings*,
- b) to existing parts of *buildings* to which additions described in Clause (a) are made, and
- c) to the extent required by Article 3.8.4.5., to existing *buildings*
 - i) where the *occupancy* is changed, or
 - ii) that are altered or renovated.>

See definition (and commentary) of “building of new construction” on page 1.

2) This Subsection does not apply to

- a) <*buildings* of new construction,
- b) vertical additions of one *storey* not more than 600 m² in *floor area* regardless of *occupancy*, or
- c) horizontal or vertical additions to *occupancies* described in Clauses 3.8.2.1.(2)(b) to (e).>

See comment under “building of new construction.” definition. [p. 1]

3.8.4.2. Specific Requirements

1) Exterior *access* shall be provided to an addition except where *access* to the addition is provided by way of the existing *building*.

2) Walks and ramps for an addition shall conform to Subsection 3.8.3.

3) A main entrance to an addition shall be *accessible* except where the addition is *accessible* by an *accessible* path of travel from an *accessible* main entrance serving the existing *building*.

Where an addition is made to a building and the addition incorporates one or more main entrances it is preferred that they be accessible. However, in some instances providing access directly to an addition may not be practical for design or economical reasons. Article 3.8.4.2. allows access to be provided to the addition by way of the existing building. Where access is provided through the existing building, discretion should be shown in requiring access routes to conform to the requirements of Subsection 3.8.3. For example, an existing ramp may not meet the width requirement of 1 500 mm but providing it is wide enough for a wheelchair to negotiate (at least 915 mm), it would be excessive to require such a ramp to be increased in width.

3.8.4.3. Vertical Additions

- 1) Where there is a vertical addition of one *storey* and of more than 600 m² in *floor area*, or of two or more *storeys* regardless of *floor area*,
- a) *access* shall be provided to all additional *storeys*, and
 - b) the additional *storeys* shall conform to Subsections 3.8.2. and 3.8.3.

Where storeys are added to a building and the existing upper storeys of the building are already served by elevators it should not be taken as mandatory that the elevators, when used to service the added storeys, be brought up to the requirements for accessible elevators.

However, if the elevators are voluntarily upgraded, the work that is done should conform to the requirements in Appendix E of the Safety Code for Elevators wherever possible. It may not be feasible, for instance, to have a new control panel conform to the requirements because of dimensional limitations or incompatibility with the existing wiring.

3.8.4.4. Horizontal Additions

- 1) Where an existing *building* is extended horizontally, the requirements of Subsections 3.8.2. and 3.8.3. shall be applied to the addition except as described in Articles 3.8.4.2., 3.8.4.6., and Sentence 3.8.4.8.(2).

3.8.4.5. Alterations and Occupancy Change

- 1) Where an existing *building* is altered or renovated, or where the *occupancy* is changed, *access* shall be provided in conformance with Subsections 3.8.2. and 3.8.3. where,
- a) *persons with disabilities* could reasonably be expected to be employed in, or could reasonably be expected to use, such an *occupancy* or *building*, and
 - b) where providing such *access* would be practical.

The general intent of Article 3.8.4.5. is to make buildings accessible when they undergo a change of use or are renovated or altered. It should be the responsibility of the owner or the owner's agent to demonstrate to the building official that the building would not be used by persons with disabilities or providing access would be impractical.

It is rare for it to be unreasonable for persons with disabilities to be employed in or use any occupancy.

Cases where providing access to an altered or renovated building is not practical are, perhaps, more common and an example could be the renovation of a restaurant. Several steps separate the entrance from the sidewalk and there is simply no room to construct a ramp because the building is hard against the property line on the front and both sides while the rear is a full storey above the ground. Providing access to this building could be considered impractical based on the difficulty and high cost of installing a lift or an elevator.

3.8.4.6. Sleeping Units

1) Where sleeping units are provided in an addition, the percentage of *accessible* sleeping units required by Subsection 3.8.2. to conform to Article 3.8.3.14. shall be based on the sum of sleeping units in the addition and in the existing *building*.

2) The *accessible* sleeping units required by Sentence (1) may be distributed between the addition and the existing *building*.

It is preferred that a broad selection of the types of units available be made accessible. (see commentary to Article 3.8.3.14., page 66)

3.8.4.7. Existing Facilities

1) Where an addition is required to be *accessible*, *facilities* located in the existing *building* <that> are necessary to the operation of the addition shall be *accessible*.

It may be that facilities such as washrooms, a cafeteria or locker areas which are located in the existing part of a building, are sufficient to accommodate the occupant needs of an addition. Therefore, no such facilities are incorporated into the addition and the existing facilities are required to be accessible.

3.8.4.8. Egress from Floor Areas

1) The egress requirements of Article 3.8.3.19. shall apply to the vertical additions described in Sentence 3.8.4.3.(1).

2) Where an existing *storey* is extended horizontally, the egress requirements of Article 3.8.3.19. shall apply to

- a) the extended portion of the *storey*, or
- b) the combined area of the existing *storey* and the extension.

3.8.5. Adaptable Dwelling Units**3.8.5.1. Application**

1) This Subsection applies to

- a) the design and construction of one storey adaptable dwelling units in multiple unit residential *occupancy buildings* <that> employ interior corridors or exterior passageways for access to the *dwelling units*, and
- b) the paths of travel and common *facilities* intended for use by the residents.

3.8.5.2. Construction Requirements

1) The construction of *adaptable dwelling units* and the *buildings* in which they are located shall conform to the requirements in this Subsection and <to> *access* requirements for *residential occupancy buildings* elsewhere in this Code.

3.8.5.3. Building Access Requirements

1) *Buildings* containing *adaptable dwelling units* shall

- a) conform to Article 3.8.2.27., and
- b) provide *access* to all common *facilities*.

2) Corridors and passageways providing *access* to *adaptable dwelling unit* entrances and common *facilities* shall

- a) be not less than 1 220 mm in width, and
- b) provide a clear area not less than 1 500 mm by 1 500 mm
 - i) adjacent to the elevator entrance, and
 - ii) at intervals not exceeding 10 m where the corridor or passageway exceeds 10 m measured from the elevator entrance to the end of the corridor or passageway.>

3) Except as permitted in Sentence 3.8.5.4.(1), doorways in the *accessible* path of travel throughout the *building* shall have a clear opening width not less than 850 mm.

3.8.5.4. Adaptable Dwelling Unit Doorways

1) Within an *adaptable dwelling unit*, doorways providing *access* to common living areas and at least one bathroom and one bedroom shall have a clear opening width of not less than 800 mm.

2) Floor space on both sides of the bathroom and bedroom doors referred to in Sentence (1) shall conform to Clause 3.3.1.13.(10)(b).

3.8.5.5. Adaptable Dwelling Unit Bathrooms

1) The bathroom referred to in Sentence 3.8.5.4.(1) shall be designed to be adaptable for use by persons in wheelchairs by providing

- a) a dimension from the front edge of the toilet to the facing wall of not less than 800 mm,
- b) a dimension from the front face of the bathtub or shower to the centre line of the toilet not less than 510 mm, and
- c) a clear floor area in front of the lavatory not less than 760 mm wide by 1 220 mm deep centred on the lavatory.

2) Walls adjacent to the toilet and bathtub or shower shall accommodate the future installation of grab bars conforming to Clauses 3.7.2.10.(4)(a) and (j) or 3.7.2.10.(11)(j) which will resist a vertical and horizontal load of not less than 1.3 kN. (See Appendix A.)

3.8.5.6. Adaptable Dwelling Unit Kitchens

1) The kitchen in an *adaptable dwelling unit* shall be designed so that the range and sink are adjacent or can have a continuous counter between them.

3.8.5.7. Outlets, Switches and Controls

1) Electrical, telephone, cable and data outlets intended for use by the occupants shall be located between 455 mm and 1 200 mm above the floor.

2) Switches and controls intended for occupant use shall be located between 900 mm and 1 200 mm above the floor.

Appendix 1

Figure A.3.8.1. shows dimensions of a “traditional” wheelchair still commonly in use. It is provided for general information purposes and to illustrate the need for many of the dimensional requirements contained in Section 3.8.

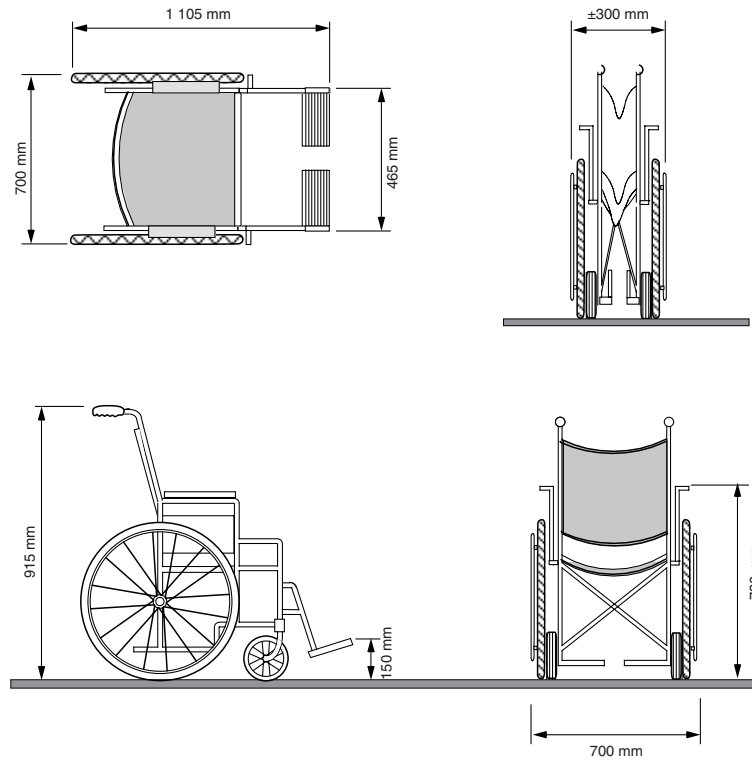
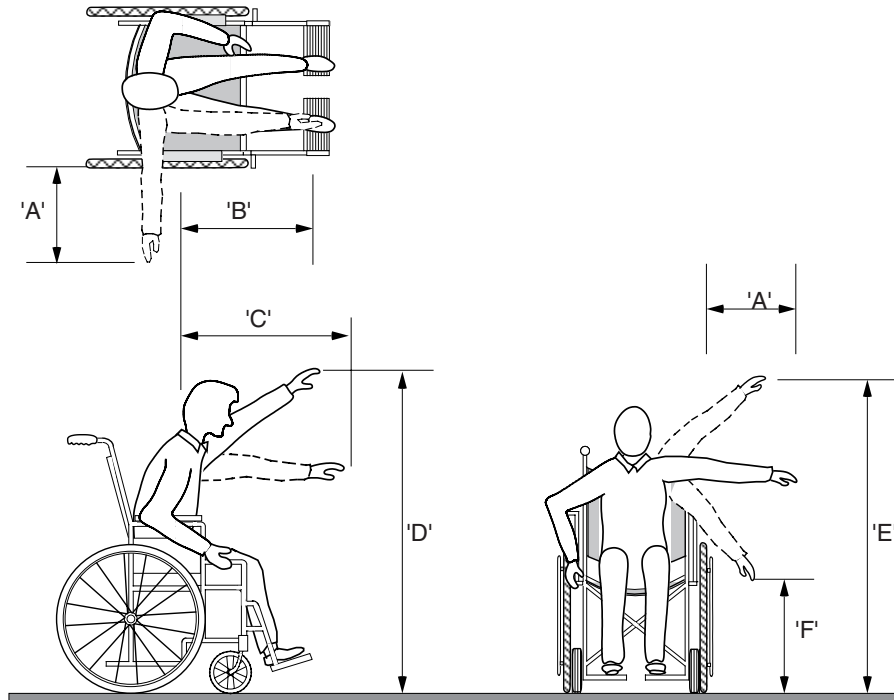

FIGURE A.3.8.1.

Appendix 2

Figures A.3.8.2. and A.3.8.3. illustrate comfortable reaches of most persons who use wheelchairs (and have full use of their upper limbs) and the reach of most persons who are fully ambulant. They are provided for general information and comparison purposes only and illustrate the need for many of the dimensional requirements for persons with disabilities contained in the B.C. Building Code. It must be realized that many persons with disabilities, especially those who use wheelchairs, do not have full upper body mobility. The extremes of reach shown in Figures A.3.8.2. and A.3.8.3. should be avoided when designing facilities because they can be useless or awkward for a significant number of persons with disabilities.



Key	Male ⁽¹⁾	Female ⁽²⁾	Child ⁽³⁾
A - Easy side reach	505 mm	439 mm	300 mm
B - Easy forward reach	541 mm	513 mm	389 mm
C - Maximum forward reach	922 mm	869 mm	668 mm
D - High reach (forward)	1410 mm	1308 mm	965 mm
E - High reach (side)	1641 mm	1506 mm	1237 mm
F - Full reach (down)	338 mm	439 mm	508 mm
Column 1	2	3	4

Notes to Table B.3.7.1.A. (1) Male height – 1740 mm
 (2) Female height – 1605 mm
 (3) Child (6–9 yrs) – 1245 mm

FIGURE A.3.8.2. – Reach of Persons in Wheelchairs

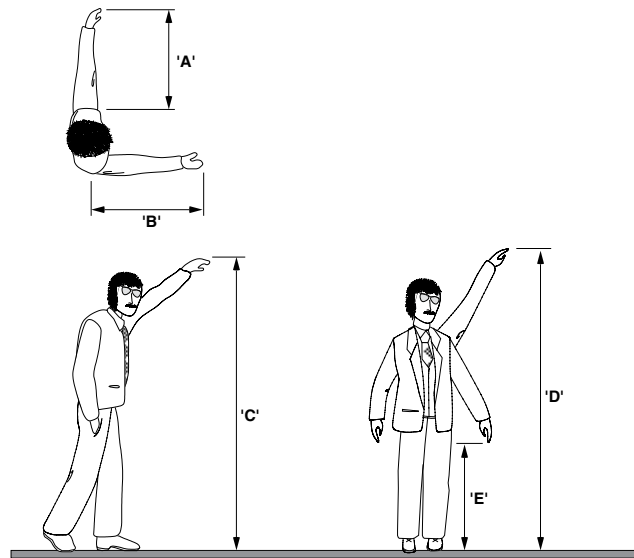

Key	Male ⁽¹⁾	Female ⁽²⁾	Child ⁽³⁾
A Side reach	727 mm	673 mm	524 mm
B Forward reach	638 mm	592 mm	462 mm
C High reach (forward)	1928 mm	1786 mm	1372 mm
D High reach (side)	2002 mm	1849 mm	1423 mm
E Low reach (side)	762 mm	665 mm	499 mm
Column 1	2	3	4

Notes to Table B.3.7.2.A. (1) Male height – 1740 mm
 (2) Female height – 1605 mm
 (3) Child (6–9 yrs) – 1245 mm

FIGURE A.3.8.3. – Reach of Ambulant Person

Appendix 3

Classification of Building Use

The Building Code classifies buildings according to their use. The purpose of classification is to establish which code requirements are applicable. Most buildings are classified as containing a single major occupancy although there are usually other “minor” occupancies in the building which are integral with the major occupancy and considered subsidiary to it. If a building contains more than one major occupancy, such as a hotel (Group C, residential) with restaurants and conference rooms on the main floor (Group A, assembly), the Code stipulates the building must comply with the requirements for each major occupancy it contains.

The following are examples of the major occupancy classifications described in Table 3.1.2.1. of the British Columbia Building Code and referred to throughout this Handbook:

Group A, Division 1 Assembly

Motion picture theatres

Theatres, including experimental theatres

Opera houses

Television studios admitting a viewing audience

Group A, Division 2 Assembly

Art galleries
 Auditoria
 Bowling Alleys
 Churches and similar places of worship
 Museums
 Passenger stations and depots
 Recreational piers
 Restaurants
 Schools and colleges, Non-residential
 Undertaking Premises

Gymnasia
 Lecture halls
 Libraries
 Licensed beverage establishments
 Clubs, non-residential
 Community halls
 Court rooms
 Dance halls
 Exhibition halls
 (other than classified in Group E)

Group A, Division 3 Assembly

Arenas
 Rinks

Indoor swimming pools with or without
 spectator seating

Group A, Division 4 Assembly

Amusement park structures
 (not elsewhere classified)
 Bleachers

Grandstands
 Reviewing stands
 Stadia

Group B, Division 1 Institutional

Jails
 Penitentiaries
 Police stations with detention quarters

Prisons
 Psychiatric hospitals with detention quarters
 Reformatories with detention quarters

Group B, Division 2 Assembly

Children's custodial homes
 Convalescent homes
 Hospitals
 Infirmarys
 Nursing homes
 Sanitoria without detention quarters

Orphanages
 Psychiatric hospitals without detention
 quarters
 Reformatories without detention quarters

Group C Residential

Apartments
 Boarding houses
 Clubs, residential
 Colleges, residential
 Convents
 Dormitories

Hotels
 Houses
 Lodging houses
 Monasteries
 Motels
 Schools, residential

Group D

Business and Personal Service

Banks	Laundries, self-service
Barber and hairdressing shops	Medical offices
Beauty parlours	Offices
Dental offices	Police stations without detention quarters
Dry-cleaning establishments, self-service, not using flammable or explosive solvents or cleaners	Radio stations
	Small tool and appliance service establishments

Group E

Mercantile

Department stores	Shops
Exhibition halls	Stores
Markets	Supermarkets

Group F, Division 1

Industrial, High Hazard

Bulk plants for flammable liquids	Flour mills
Bulk storage warehouses for hazardous substances	Grain elevators
Cereal mills	Lacquer factories
Chemical manufacturing or processing plants	Mattress factories
Distilleries	Paint, varnish and pyroxylin product factories
Dry-cleaning plants	Rubber processing plants
Feed mills	Spray painting operations
	Waste paper processing plants

Group F, Division 2

Industrial, Medium Hazard

Aircraft hangars	Mattress factories
Box factories	Planing mills
Candy plants	Printing plants
Cold storage plants	Repair garages
Dry-cleaning establishments not using flammable or explosive solvents or cleaners	Sales rooms
Electrical substations	Service stations
Factories	Storage rooms
Freight depots	Television studios not admitting a viewing audience
Warehouses	Helicopter landing areas on roofs
Wholesale rooms	Woodworking factories
Laboratories	Workshops
Laundries except self-service	

Group F, Division 3

Industrial, Low Hazard

Creameries	Storage garages including open air parking garages
Factories	Storage rooms
Laboratories	Warehouses
Power plants	Workshops
Sales rooms	
Sample display rooms	

Explanation of Building Height and Building Area

In order to determine what code requirements apply to a building it is necessary to determine not only its major occupancy but also its height and area. The higher and/or larger a building is the more stringent are the code's fire and life safety requirements. Building height and area also have a limited effect on access requirements.

Building height is measured in storeys above grade and is defined as "... the number of storeys contained between the roof and the floor of the first storey ..." The key here is the term "first storey" which is defined as the "...uppermost storey having its floor level not more than 2 m above grade..." This means that a storey which is partly below grade might not be included in a building's height for code classification purposes. Therefore, a building of two storeys in "building height" may contain more than two storeys, e.g. a two storey apartment block with a basement level partly above grade. Such a building is considered as two storeys in building height but contains three storeys.

Building area is defined as "...the greatest horizontal area of a building above grade within ... exterior walls or within ... exterior walls and ... firewalls..." In most cases this is the area of the first storey. It is not the sum of the areas of all the storeys in the building. The best way to describe building area for the purposes of the Building Code is to start by viewing the building from above. From this bird's eye perspective trace around the apparent outside perimeter. This will include portions of storeys that may project beyond the exterior walls of lower storeys.

		directional signs for	51
		turnstiles	34
Access		Churches	7
exterior	17	Classification of Building Use	83
interior	28	Closers on doors	33
vertical	36	Clubs	
Additions		non-residential	7
access to	77	residential	13
horizontal	78	Colleges	
vertical	78	non-residential	8
Aisles	34	residential	13
Alterations	77	Community halls	7
Apartment Buildings	12	Controls	76
Appendix 1 - Wheelchair dimensions	81	for elevators	38
Appendix 2 - Anthropometric data	82	in sleeping units	67
Appendix 3 - Explanation of Building Use, Building Height and Building Area	83	Counters	72
Application		Courthouses	7
of design requirements	17	Curb ramps	23
of Section 3.8.	1	Curbs	18
to existing buildings	77		
Arcades, amusement	7	D	
Arenas	10	Dance halls	7
Art galleries	6	Definitions of Words and Phrases	1
Assembly occupancies	6	Dental offices	15
		Design requirements	17
B		Directional signs	50
Banks	15	Door assemblies	
Barbers and Hair Dressers	15	clear opening width	31
Bathrooms	54	in series	34
Baths	63	level areas at	31
Beauty parlours	15	operating forces	33
Bed space	13	thresholds in	33
Billiard halls	7	with closers	33
Bleachers	10	Doors	
Boarding houses	3	handles for	32
Bowling alleys	6	numbers	53
Building classification	83	Dormitories	13
Business and Personal Service Occupancies	14	Drinking fountains	71
		Dry-Cleaning, Self-service	16
		E	
C		Egress	
Campground	17	from floor areas	4, 73, 79
Care facilities	12	Elevating device	36
Checkout lanes	34		

Elevators, passenger	37	to stairs	44
Entrance		Hardware for doors	32
access required	4, 77	Health Care facilities	12
directional signs for	50	Hearing impairment, persons with	47, 71, 76
main entrances	27	Highway rest areas	17
Exemptions	3	Horizontal additions	78
Exhibition halls	6	Hospitals (health care)	11, 12
Existing buildings	77	Hotels	14
Existing facilities	79	Houses, lodging	3
F		I	
Faucets		Ice rinks	10
baths	63	Industrial occupancies	
lavatories, wash basins	59, 60	Division 1	17
showers	65	Division 2 and 3	17
Financial institutions	15	Institutional occupancies (care & detention)	
Fire alarm system		Division 1	11
visual signals	47	Division 2	12
when not provided	49	Interior access	28
Fire stations	15		
Floor levels	36	L	
Food service lines	35	Laundry, Self-service	16
Fountains, drinking	71	Lecture halls	7
G		Libraries	6
Grab bars		Lodge rooms	8
exceptions	66	M	
for baths	64, 69	Medical offices	15
for showers	65	Mercantile occupancies	16
for toilets	57, 62	Merchandising establishments	34
Gradients		Mirrors	61
of ramps	20, 22	Mobile home parks	17
of walks	19	Motels	14
Grandstands	10	Museums	6
Gratings	18	N	
Guides, directional	50	Night deposit boxes	15
Gymnasiums	7	Numbering	
H		doors	53
Hairdressing		floors	54
shops	15	O	
sinks	15	Obstructions	
Handrails		in passageways	28
in elevators	40		
to ramps	22		

on ramps	20
on walks	19
Occupancies	
Assembly, Division 1	6
Assembly, Division 2	6
Assembly, Division 3	10
Assembly, Division 4	10
Business and Personal Service	14
Care & Detention, Division 1	11
Care & Detention, Division 2	12
High Hazard	17
Industrial	17
Residential occupancies	12
Offices	15
door numbers	53
Off-street parking	4, 11, 25

P

Parking	
off-street	4, 11, 25
stalls	25
Parking garages	17
Parks	17
Passageways	
floor level change	24, 30
projections in	28
ramps in	23
restricted	34
Passenger	
elevators	37
terminals	8
Paths of travel	17
Penitentiaries	11
Picnic grounds	17
Police Stations	
with detention facilities	11
without detention facilities	15
Prisons	11
Property lines	17
Psychiatric hospitals	11
Public telephones	71
Public toilets	17

R

Radio stations	15
----------------	----

Ramps	
gradients	20, 22
handrails for	22
in passageways	23
landings for	20
lengths of	20, 22
obstructions on	20
width of	20
Reach of persons in wheelchairs	82
Requirements, design	17
Requirements, specific	4, 77
Residential occupancies	12
Restaurants	8
Restricted passageways	34
Rinks	10

S

Schools	
non-residential	8
residential	13
Senior citizens residences	13
Service stations	17
Shops (mercantile occupancies)	4, 16
Showers	
arenas and ice rinks	10
clubs, non-residential	7
dormitories	14
grandstands and stadiums	10
gymnasiums	8
public washroom buildings	17
schools and colleges, non-residential	9
shower compartments	65
Signs	
directional	50
main entrance	27
Sleeping accommodation	13
Sleeping Units	
design of	66
in additions	79
parking stalls for	25
Smoke alarm	47–50
Special outlet boxes	
for visual fire alarm system	50
in apartment buildings	13
Specific requirements	4, 77

Stadiums	10
Stairs	
design of	42
handrails for	44
Stores (mercantile occupancies)	4, 16
Strobe lights	47
Swimming pools	10
T	
Tactile warning systems	46
Telephone	
exchange	15
public	71
Teller, automated	15
Teller location	15
Theatres	6
drive-in	11
motion picture	70
Thresholds	
in showers	65
maximum height	33
Toilet	
building	17
compartment	55
room at non-residential schools	9
room requirements	62
room, universal	5, 62
Tool rental/service	15
Trailer parks	17
Turnstiles	34

U	
Undertakers	9
Universal toilet room	5, 62
Urinal	61

V	
Vertical access	36
Viewing positions required	69 6-7, 9-11
Visual impairment	
door numbers	53
signs	51
tactile warning systems	46
walkways	19

W	
Walks	17
gradient of	18
obstructions	19
width	18
Warning systems	46
Wash basins	58
Washrooms	
accessories	61
required	4, 54
signs	50
Water closets	
in sleeping units	67
toilets	56
Work areas	4

Queen's Printer for British Columbia©
Victoria

7610004082

To purchase additional copies order online at: www.crownpub.bc.ca

For additional information contact us at:

Crown Publications, Queen's Printer

Toll Free: 1 800 663-6105

Email: crownpub@gov.bc.ca



QUEEN'S PRINTER
PUBLICATION SERVICES
A BRANCH *of* SHARED SERVICES BC